

MOVINGschools 001

HOW TO BUILD... TAKE DOWN... + REBUILD
(Assembly instructions for 1 module)

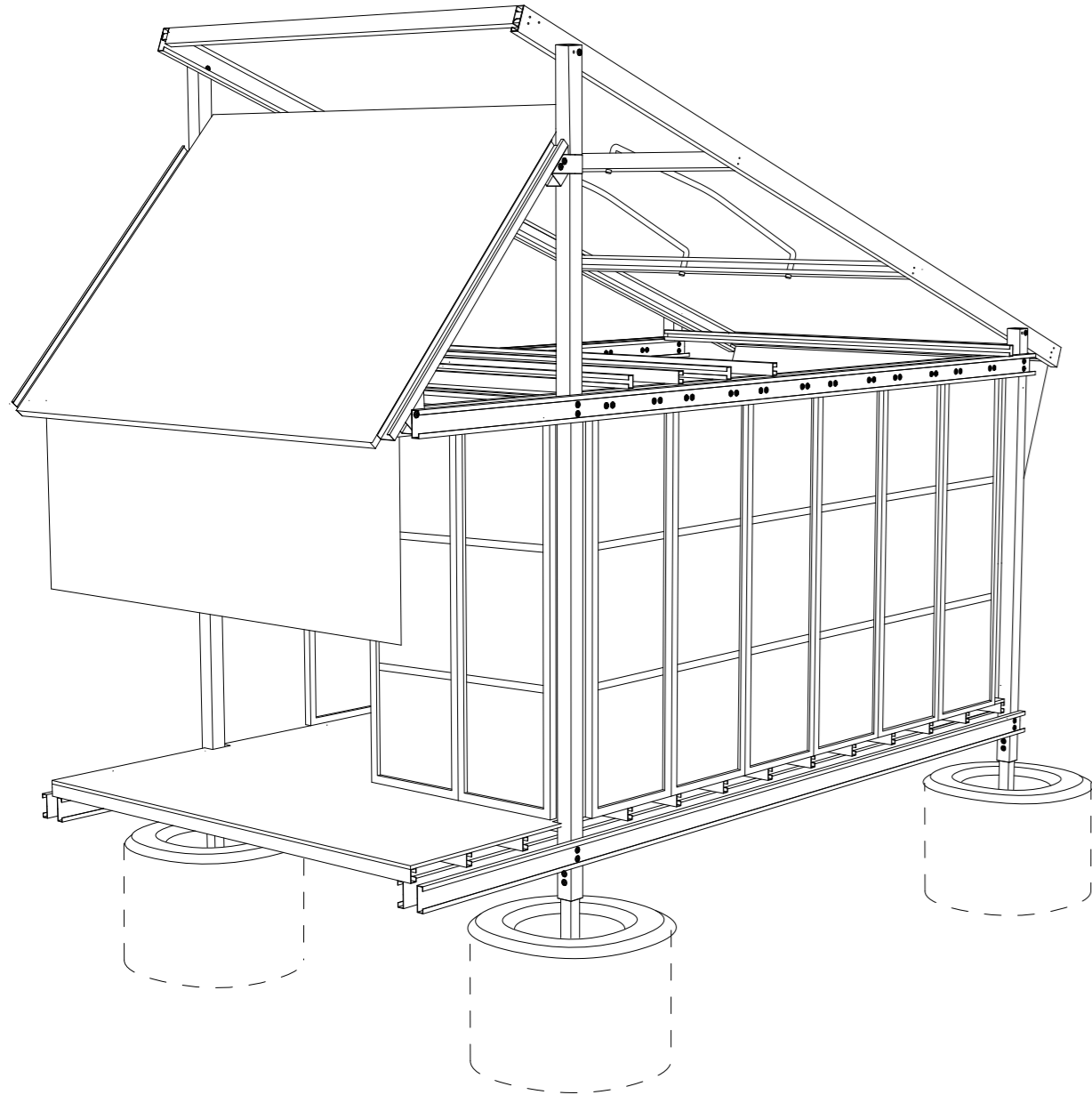

SINGLE COMPLETED MODULE



TOOLS

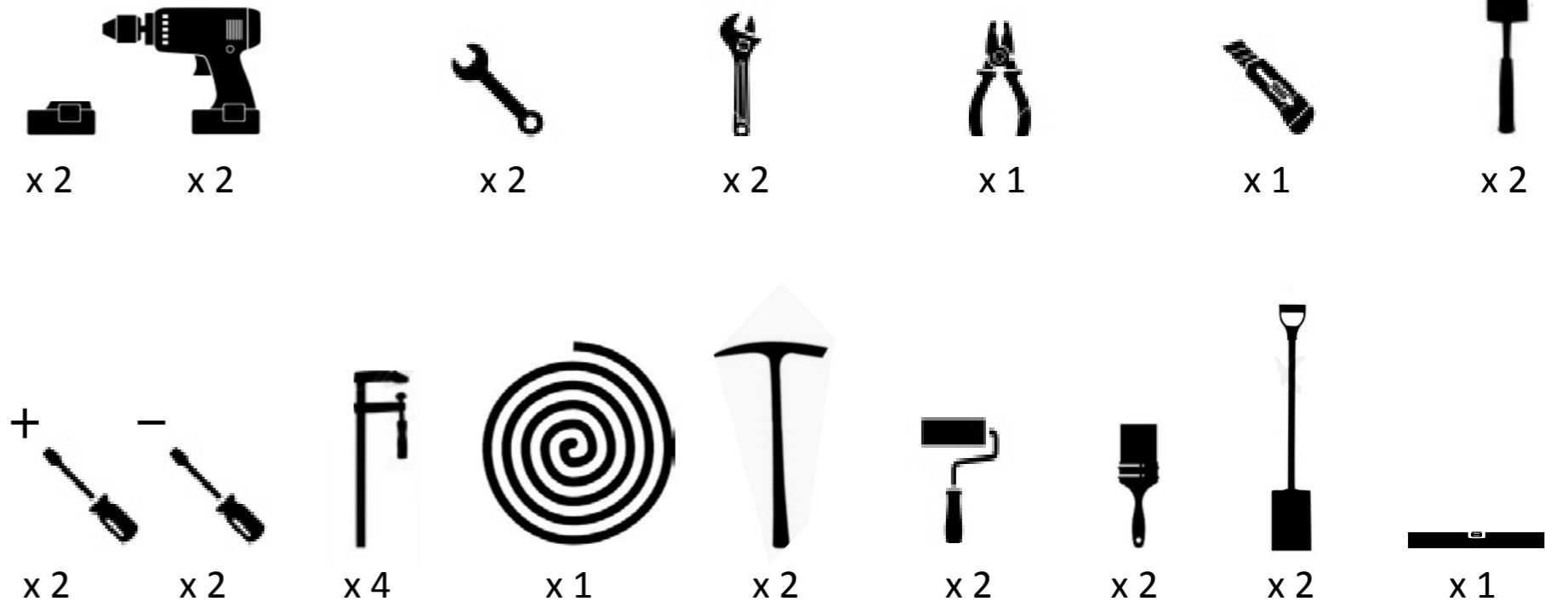

Instructions are based on one small classroom module.

MATERIALS

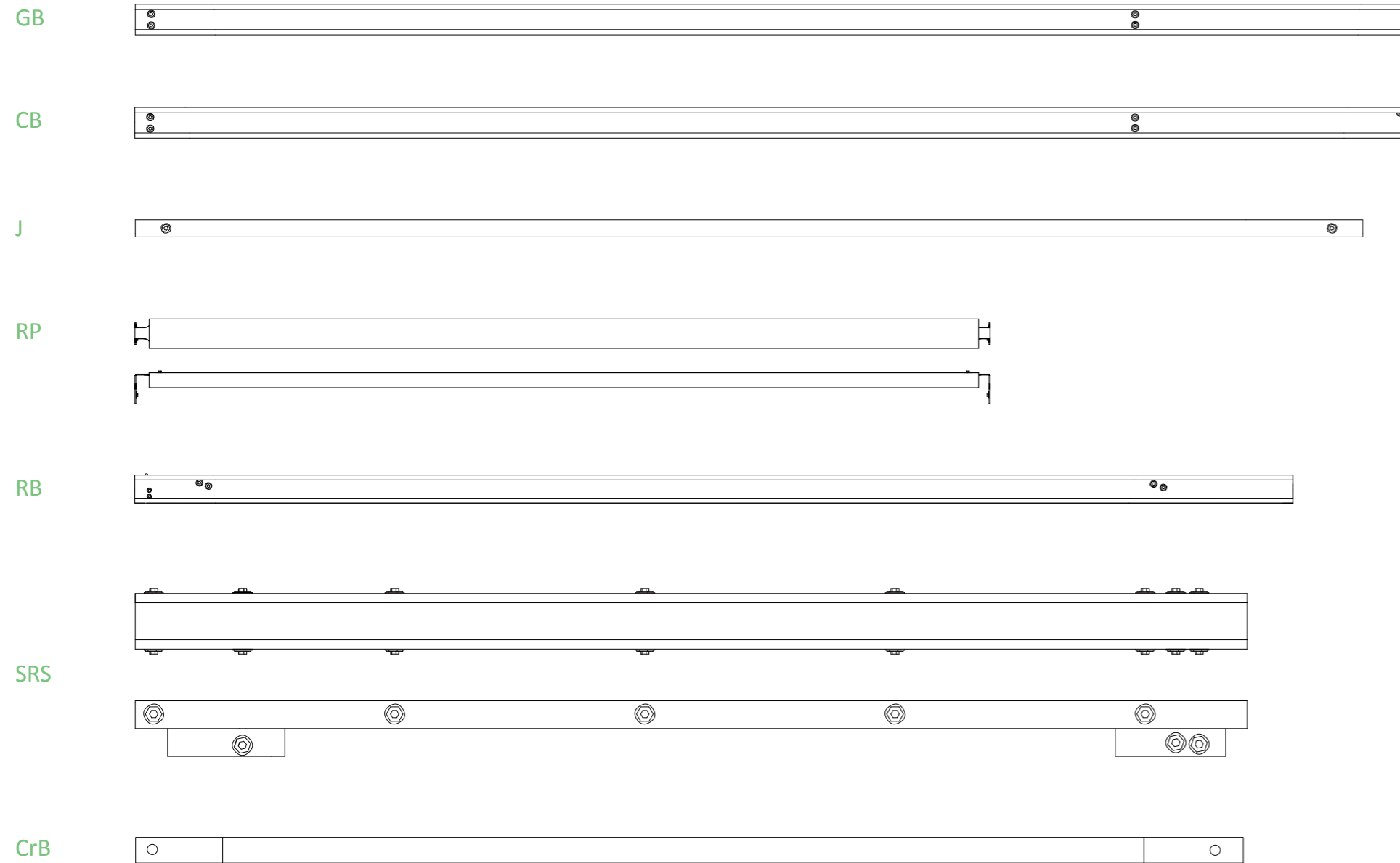

MATERIALS

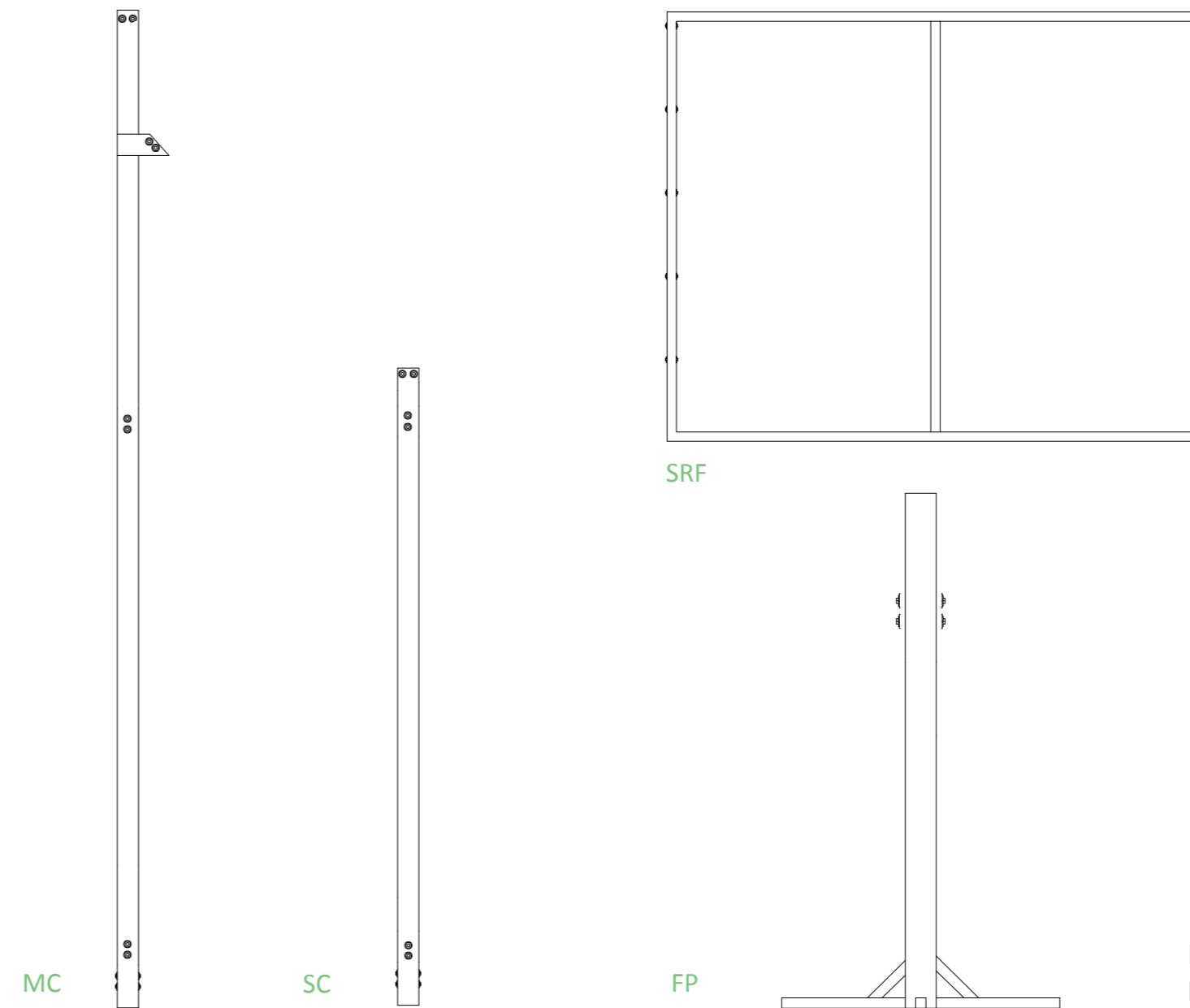

If you need to cut and drill new steel peices please see annex 1.

SITE PREPARATION

1. CHECK SITE FOR TREES

Keep trees that will help shield wind and sun
Avoid large ones that will interfere with foundations and ground swell. Dont unnecessarily fell trees

2. CHECK AXIS OF PLANNED BUILDING FOOTPRINT

Orientate West to East to reduce solar gain

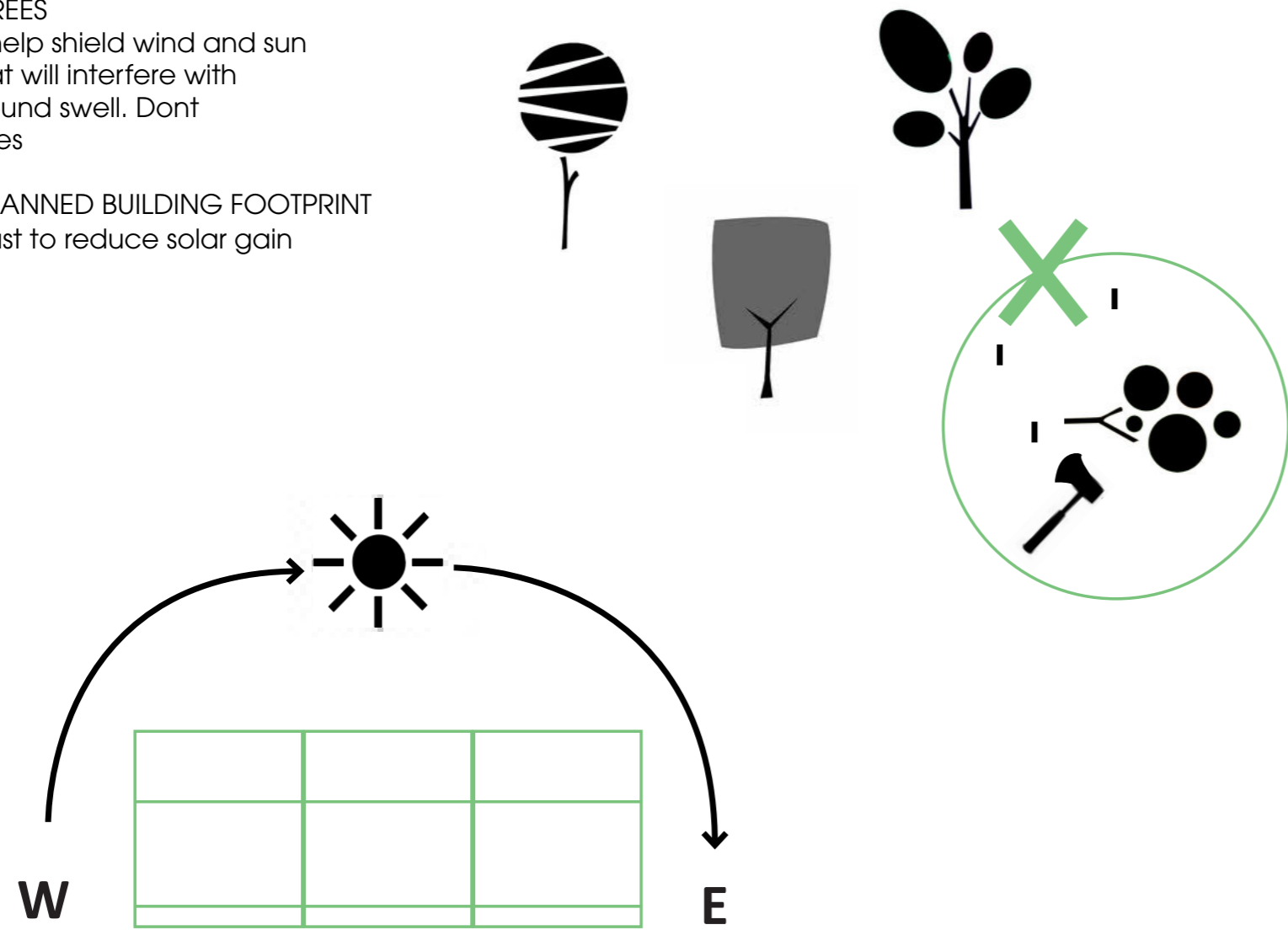

SITE PREPARATION



Partially fill clear tube with water

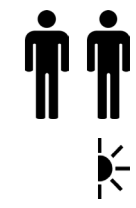
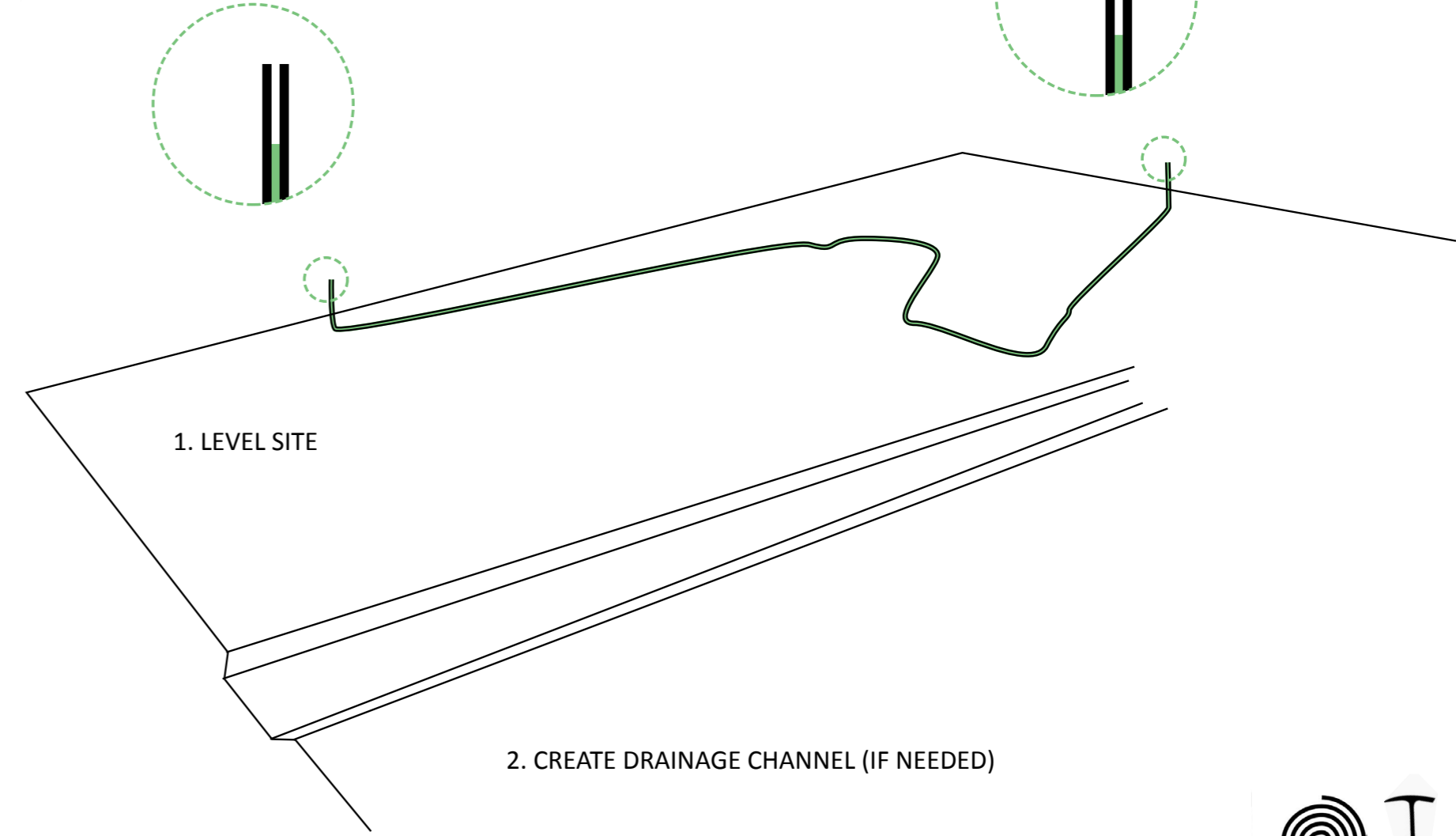

FOUNDATION POINTS

1. USE PYTHAGOREAN THEOREM

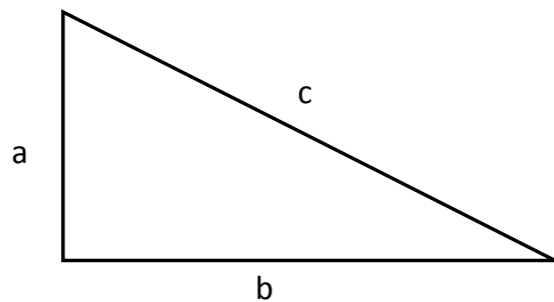

$$c^2 = a^2 + b^2$$

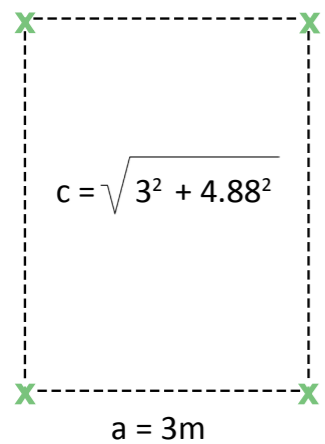
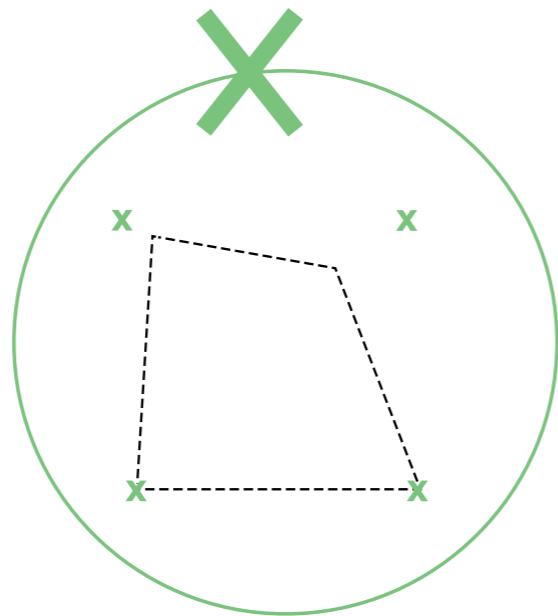

b = 4.88 m

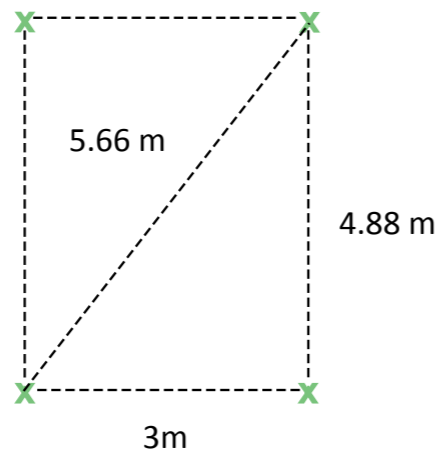
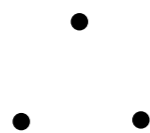

FOUNDATION POINTS

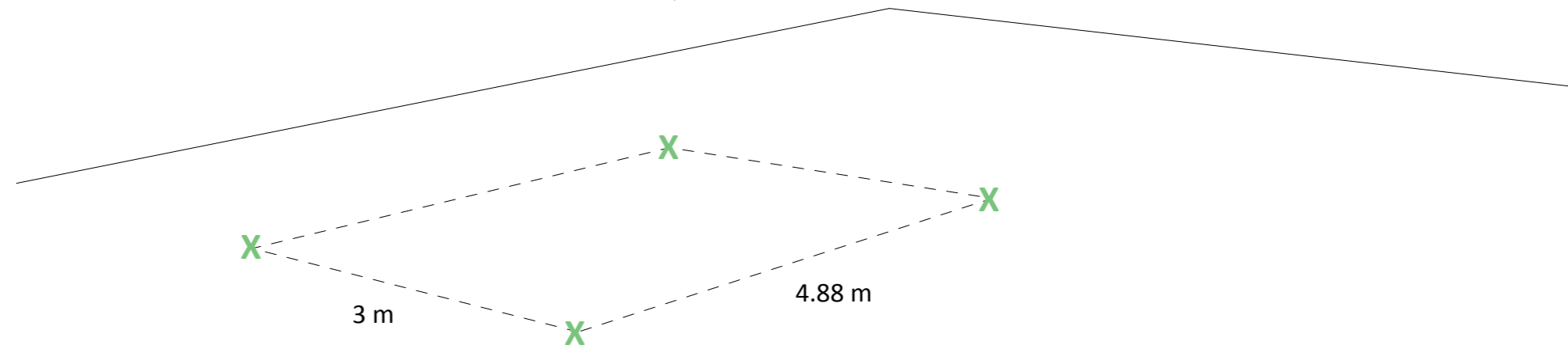
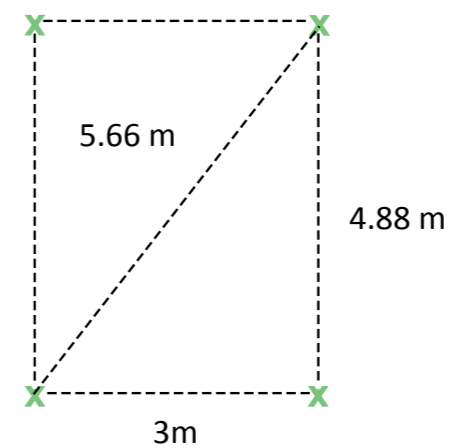

FOUNDATION HOLES

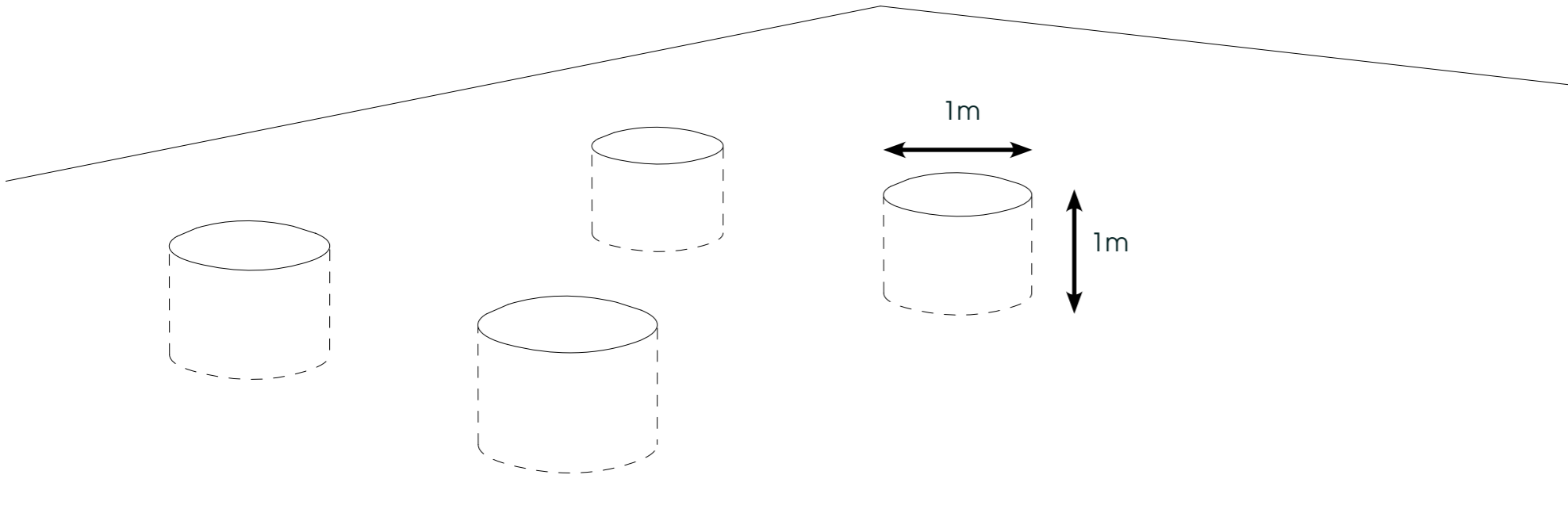
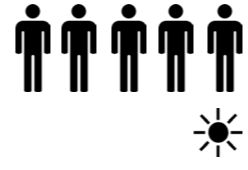

FOUNDATION SETTING

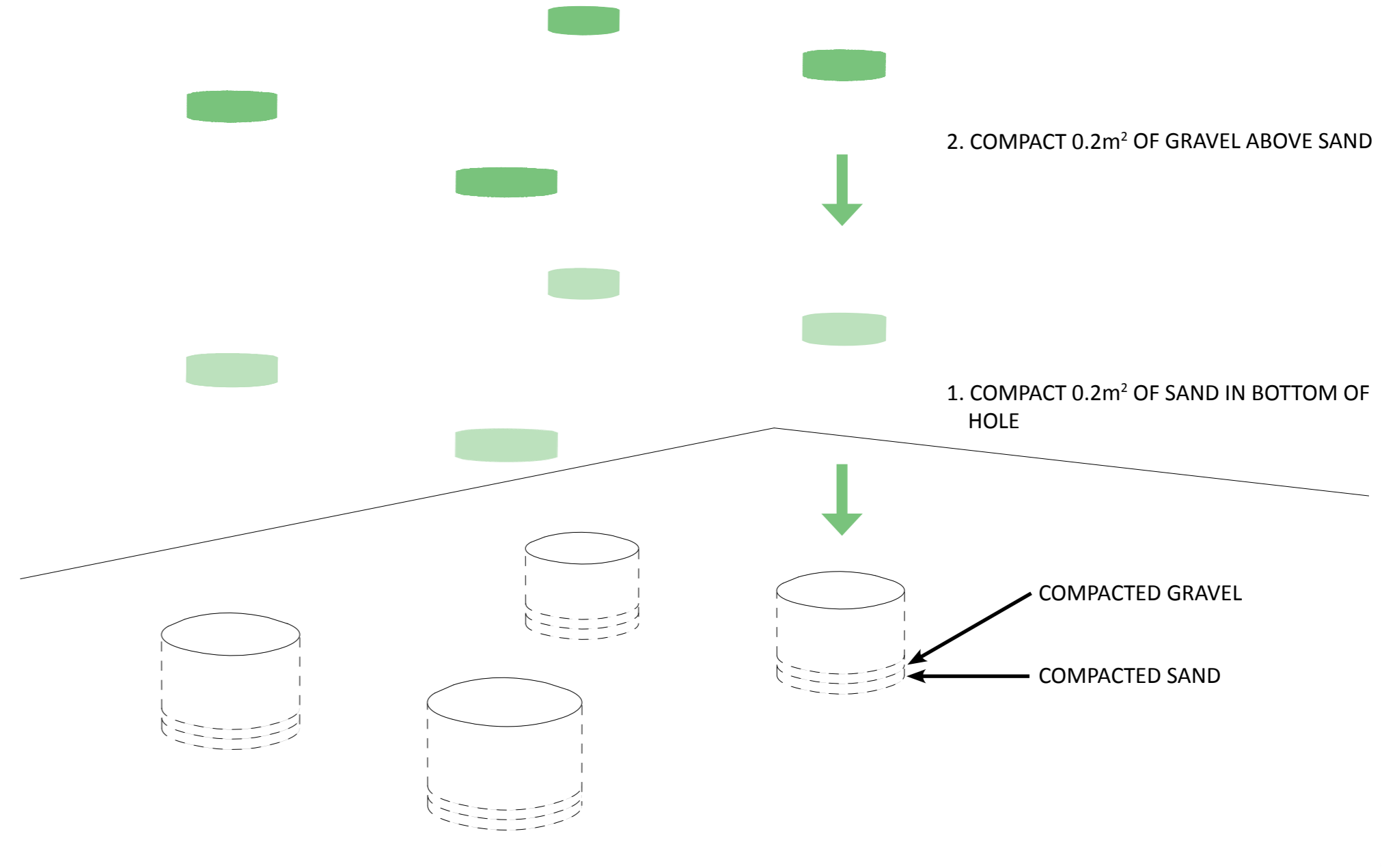
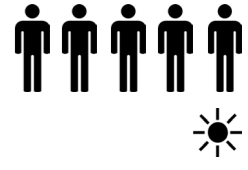

FOUNDATION FOOT DETAIL

1. PLACE FOUNDATION POSTS INTO FIRST TYRES

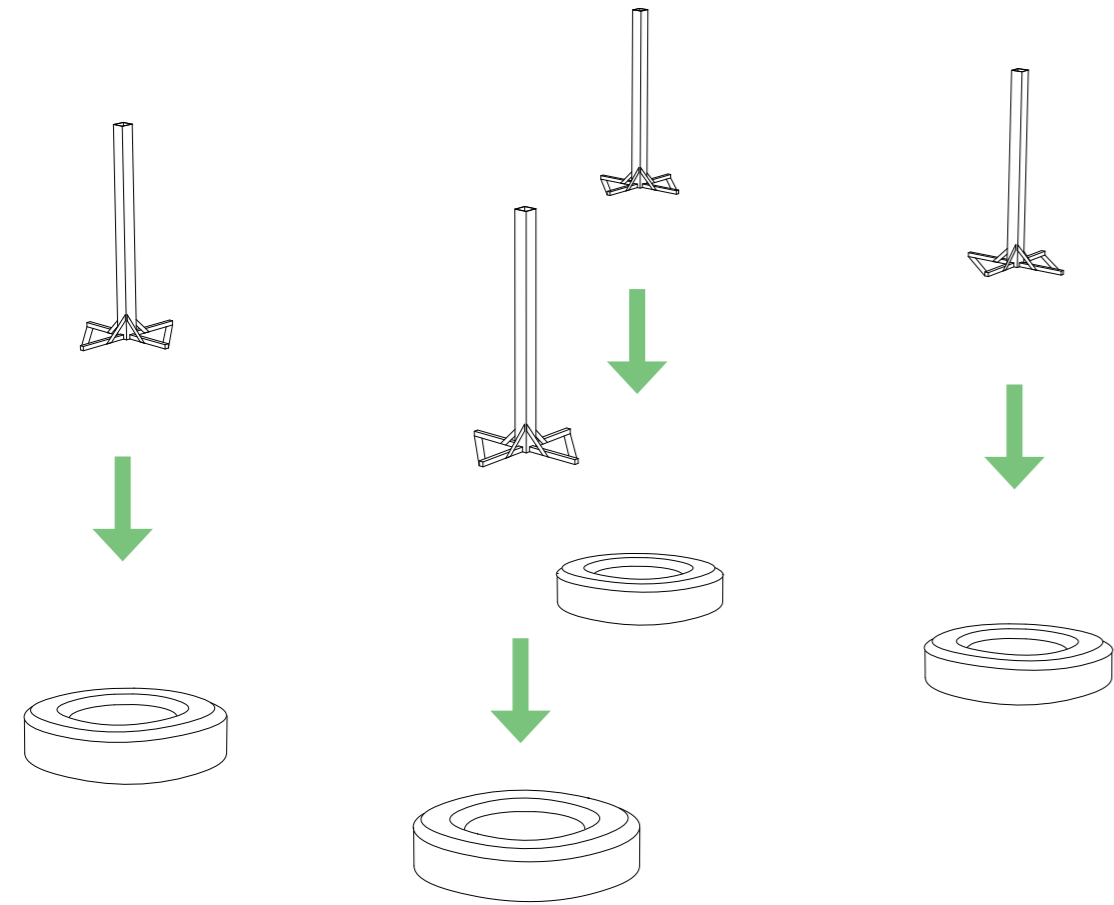

4 X FP



FOUNDATION FOOTINGS

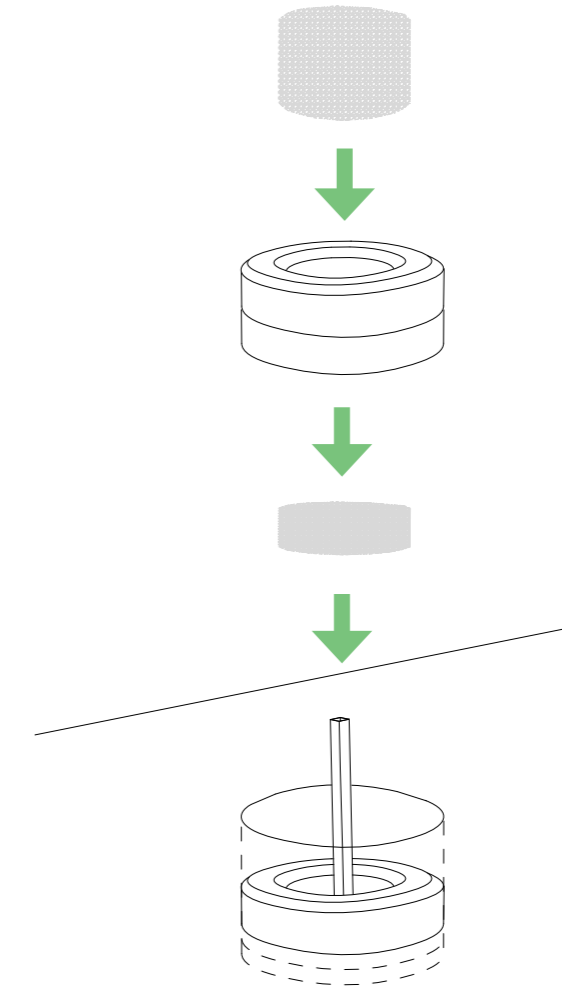

5. FILL HOLE WITH GRAVEL TO GROUND LEVEL

4. USE LEVEL TO ENSURE POST IS STRAIGHT

3. PLACE SECOND + THIRD TYRES INTO HOLES

2. FILL WITH GRAVEL TO TOP OF FIRST TYRE AND COMPACT TO FILL IN AIR POCKETS

1. PLACE POSTS + FIRST TYRES INTO HOLES



FOUNDATION FOOTINGS

1. REPEAT 3 TIMES

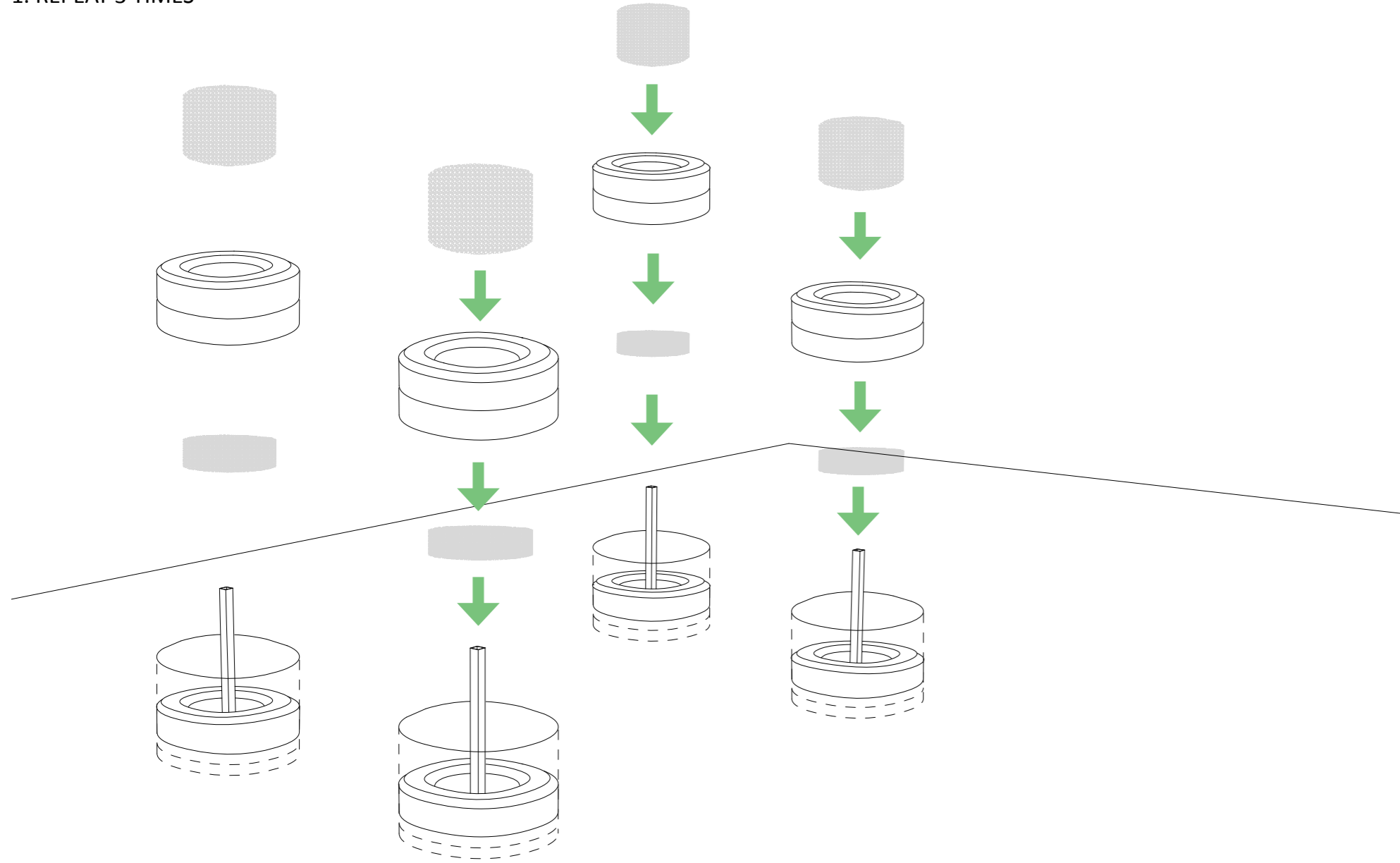

PRIMARY FRAMES

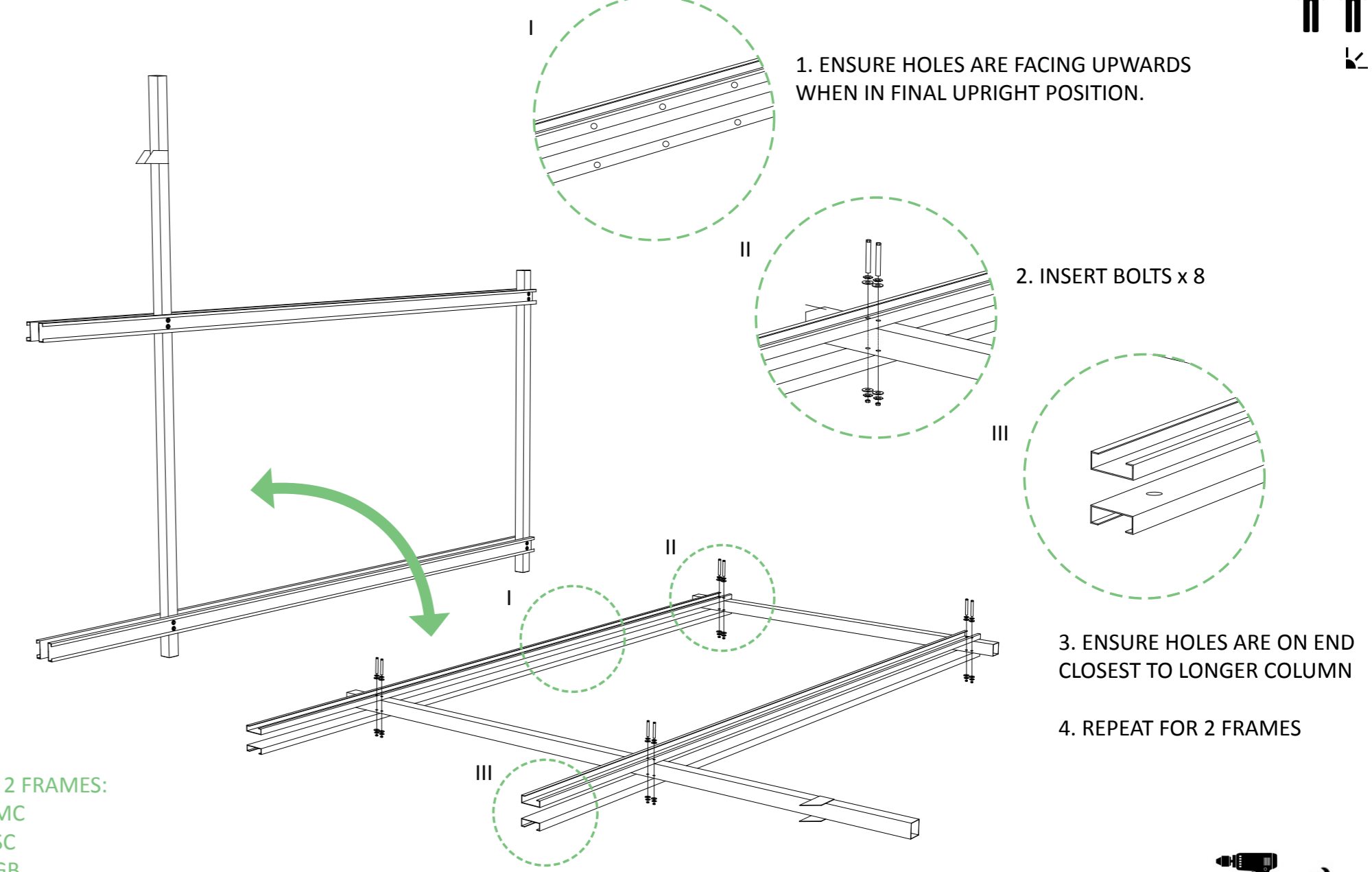
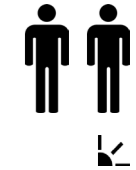

1. ENSURE HOLES ARE FACING UPWARDS WHEN IN FINAL UPRIGHT POSITION.

2. INSERT BOLTS x 8

3. ENSURE HOLES ARE ON END CLOSEST TO LONGER COLUMN

4. REPEAT FOR 2 FRAMES

FOR 2 FRAMES:
2 x MC
2 x SC
4 x GB
4 x CB



FOUNDATION FOOTING BOLT PLACEMENT

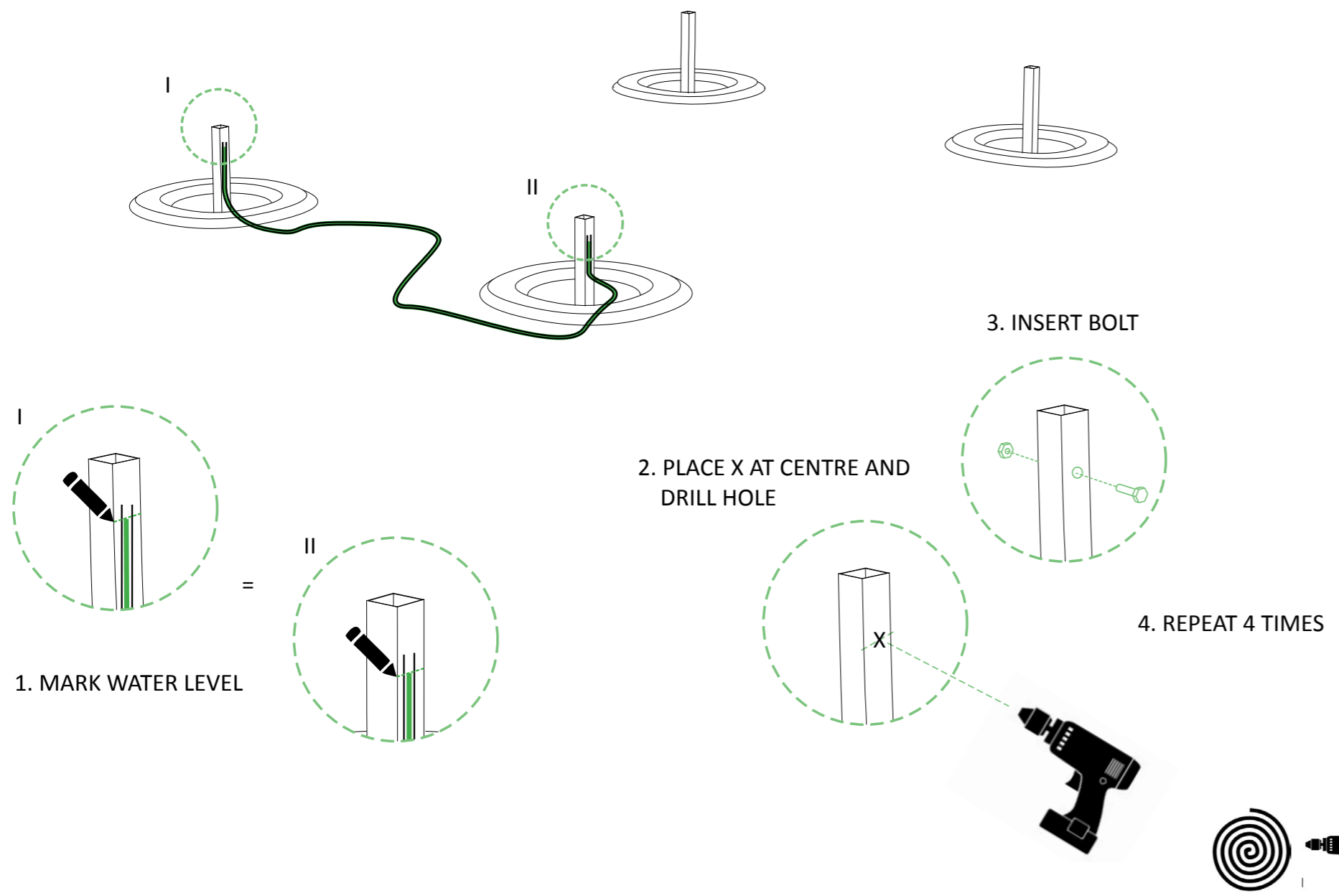
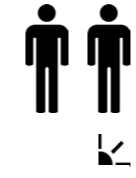

PRIMARY FRAMES ON FOUNDATION FOOTINGS

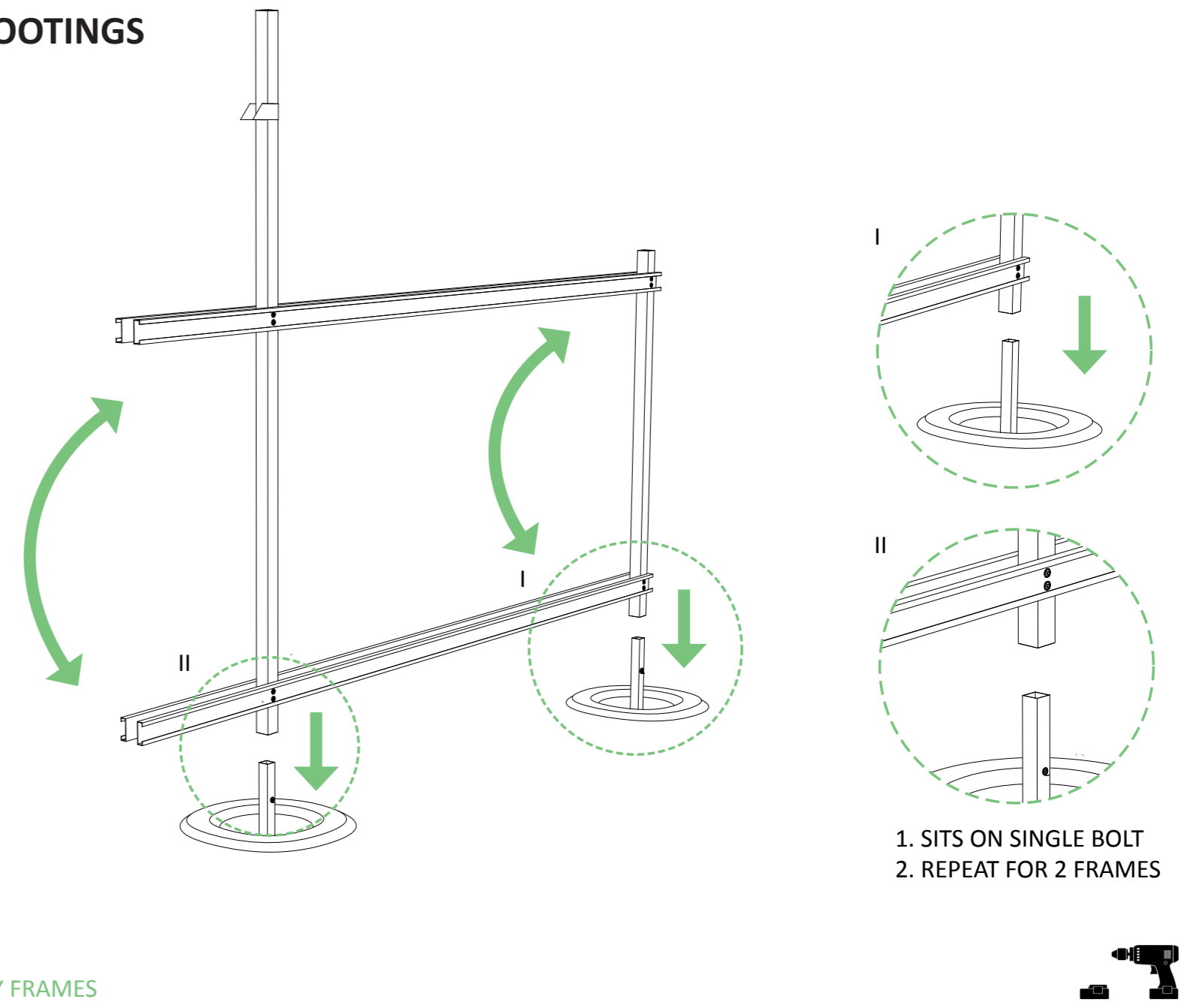
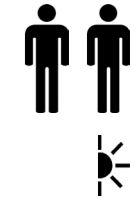

SECONDARY BOLTS ON PRIMARY FRAMES

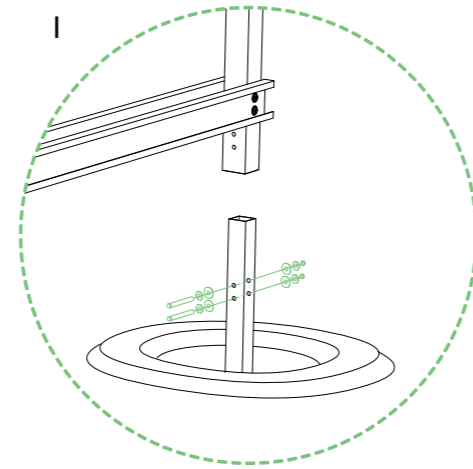
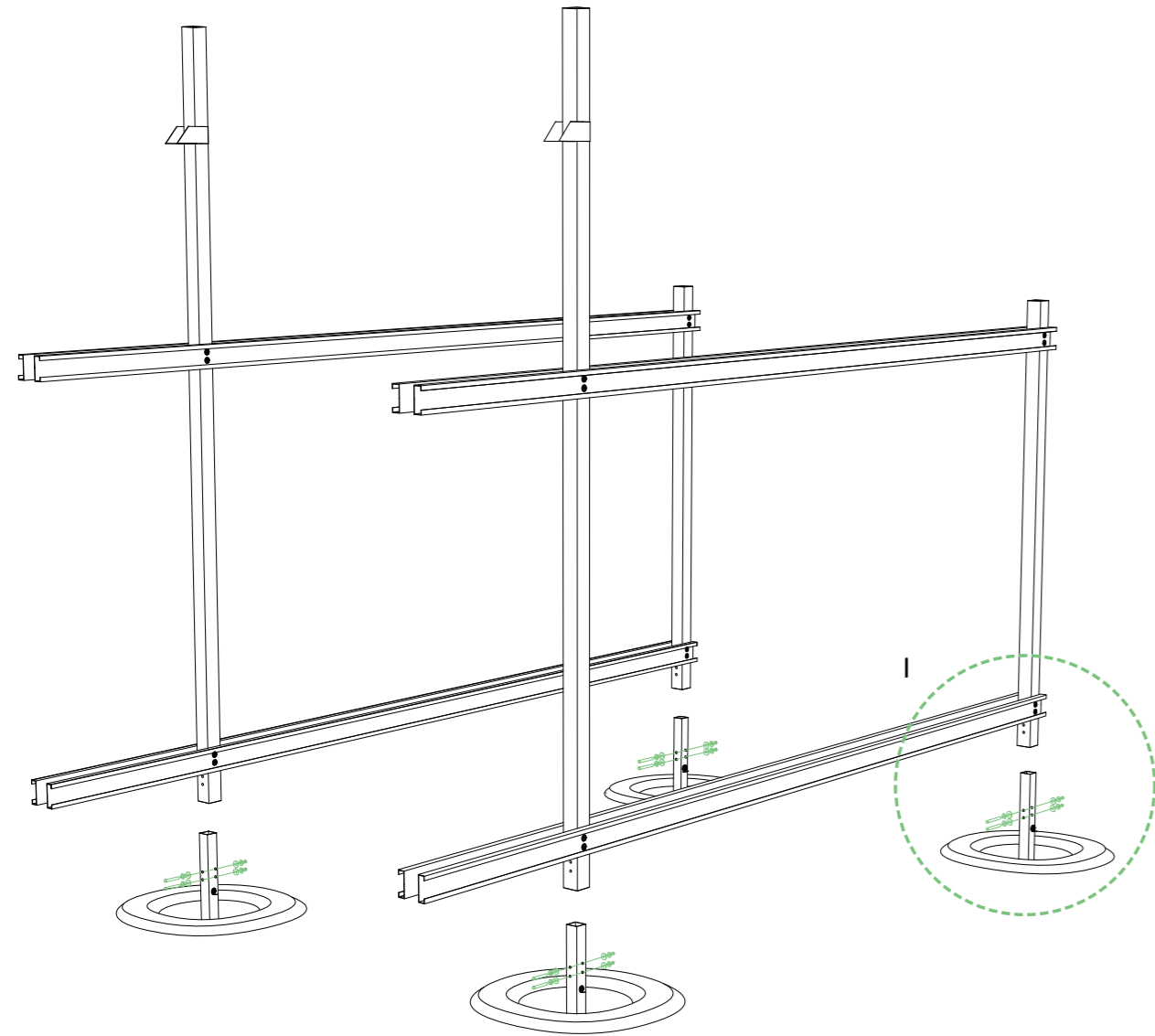

1. DRILL THROUGH GUIDE HOLES USING LEVEL TO MAKE SURE UPRIGHT
2. BOLT COLUMN TO POST
3. REPEAT 4 TIMES



TWO FLOOR JOISTS

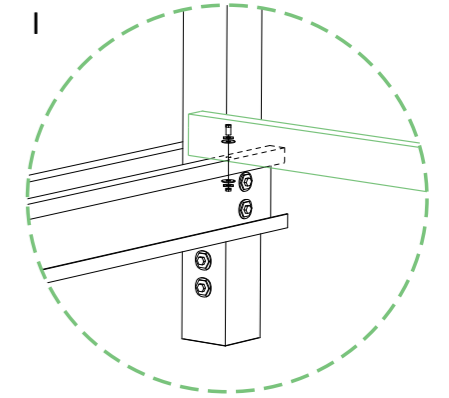
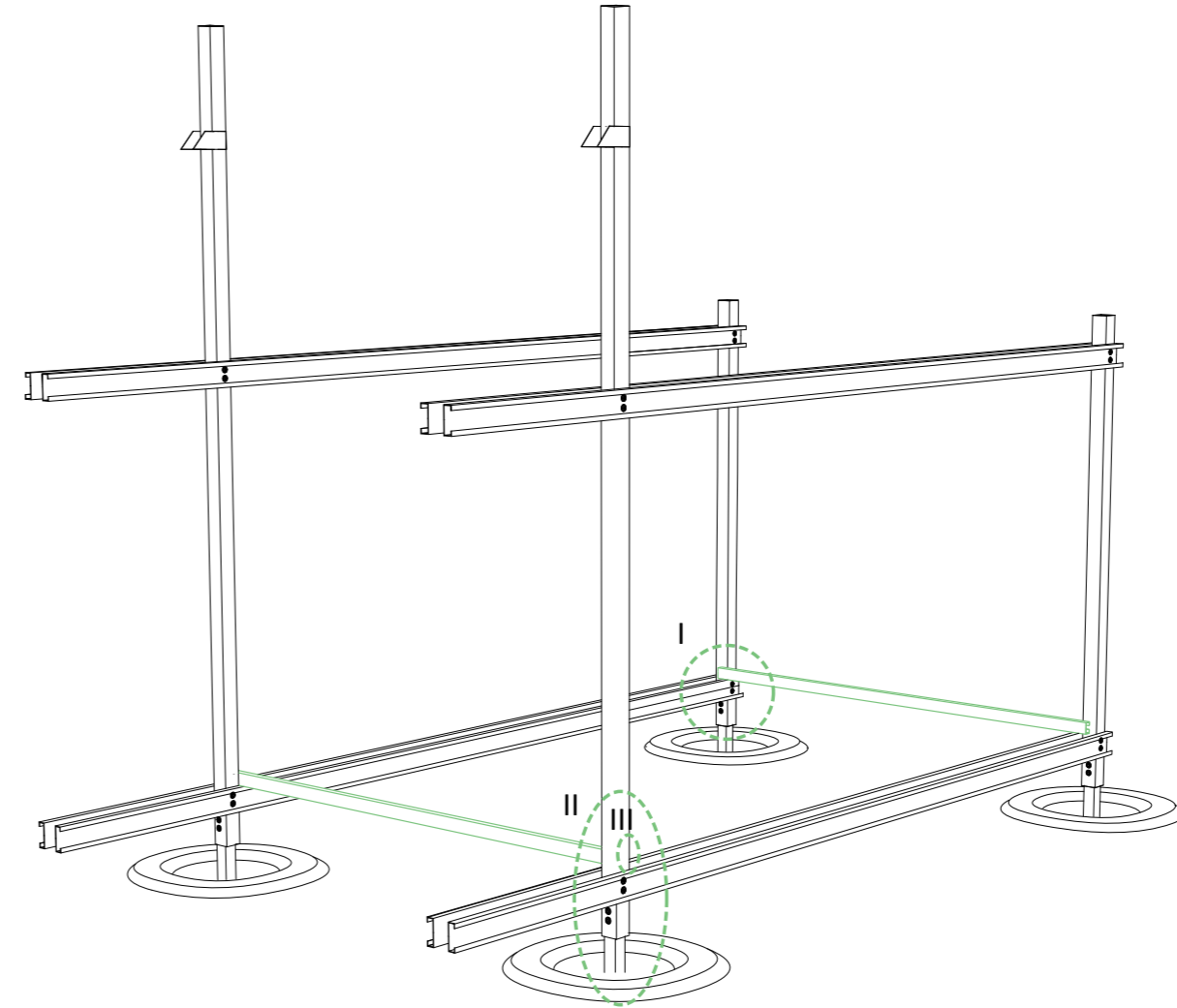
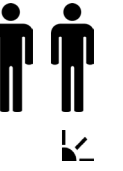

1. 1 BOLT x 2 ENDS OF JOIST
2. REPEAT FOR 2 JOISTS

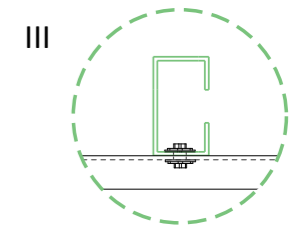
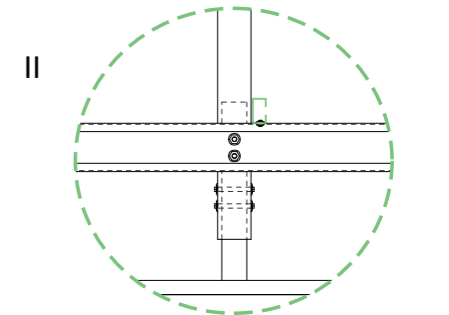

2 x J

CROSS-BRACING FOR LATERAL STABILITY

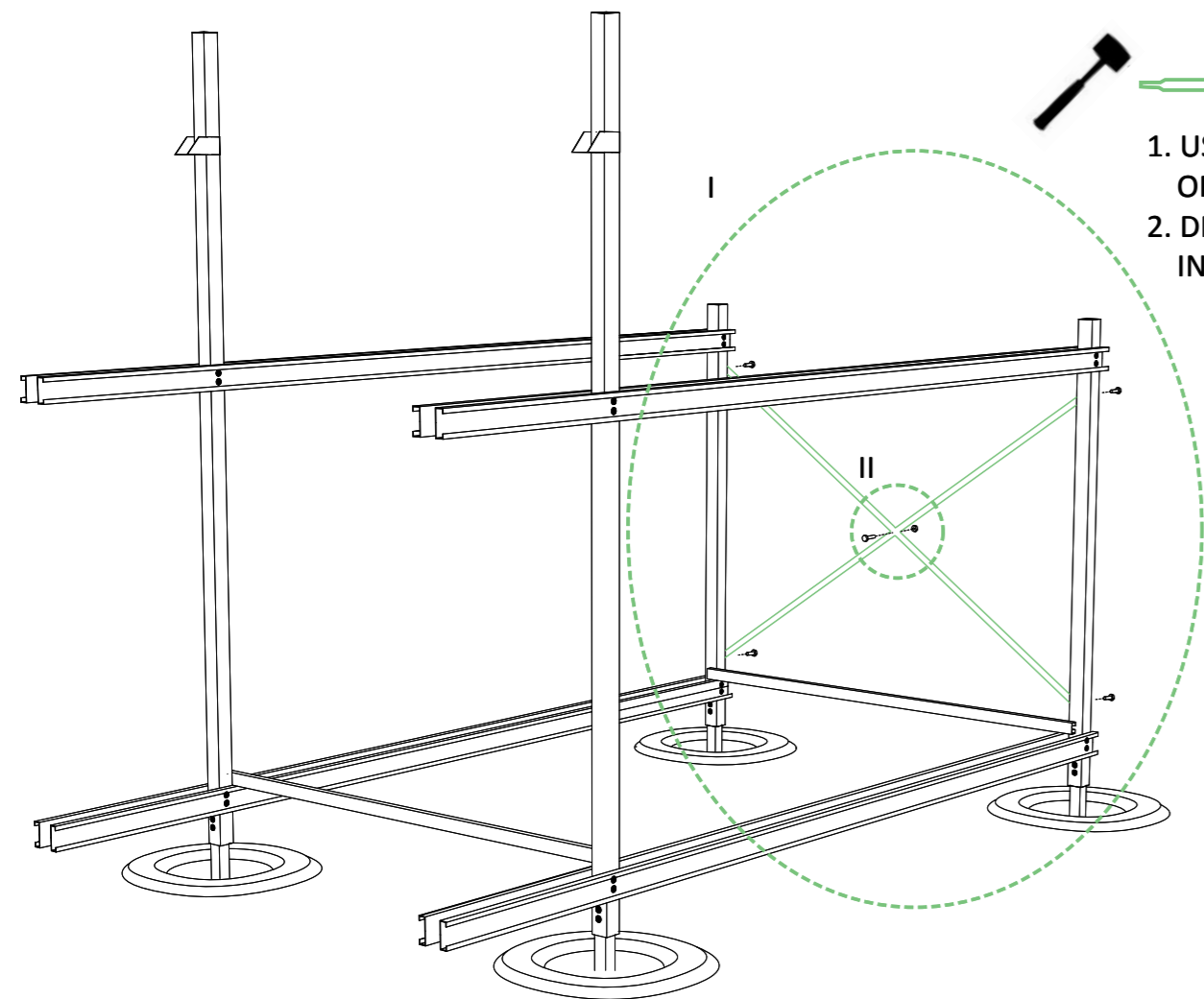

1. USE HAMMER TO FLATTEN ENDS AND MIDDLE OF BOTH CrB'S
2. DRILL HOLES 50mm FROM EACH END AND IN THE MIDDLE

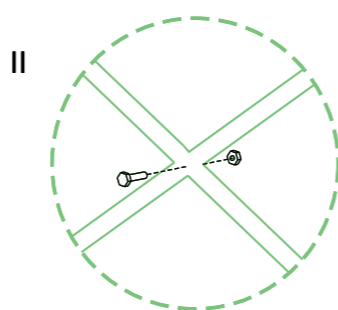
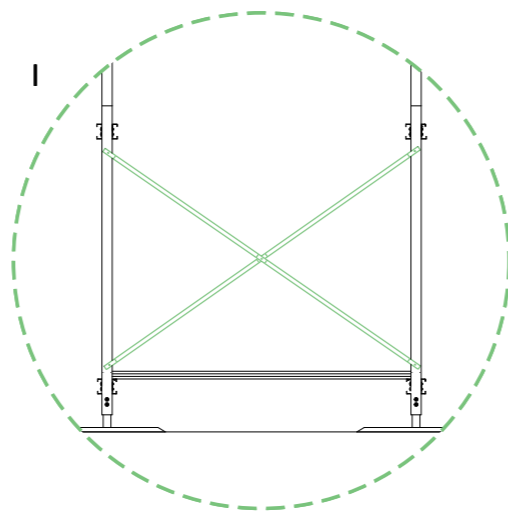

2 x CrB

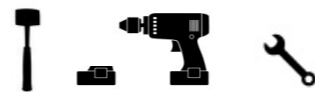

REMAINING FLOOR JOISTS

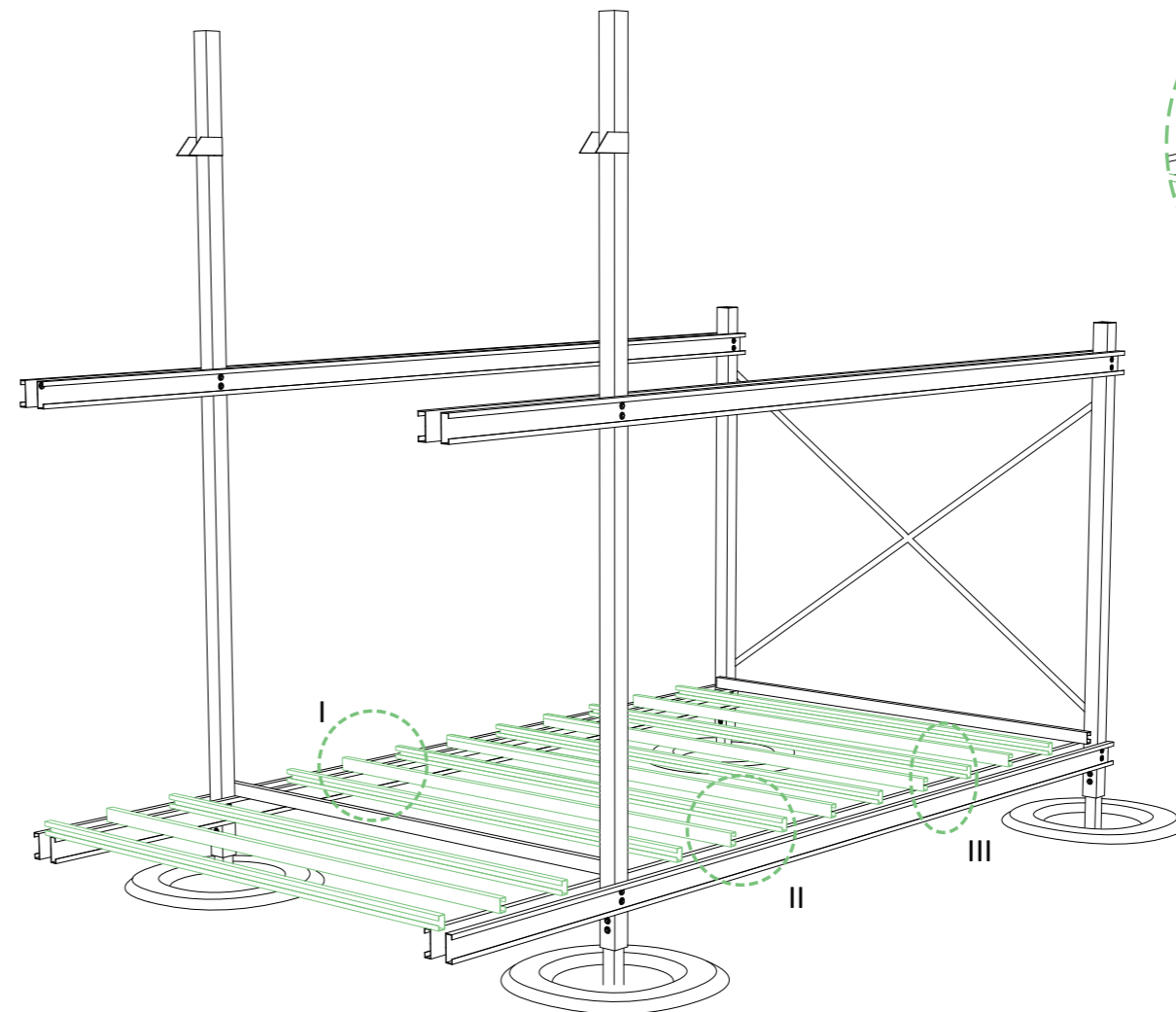

1. USE ONE M8 BOLT AT EACH END OF THE JOIST
2. ENSURE JOISTS FACE EACH OTHER (III)
3. REPEAT FOR 12 JOISTS

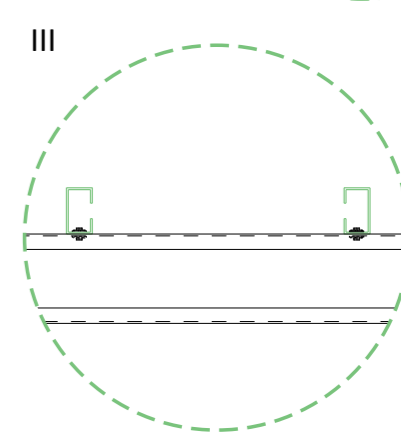
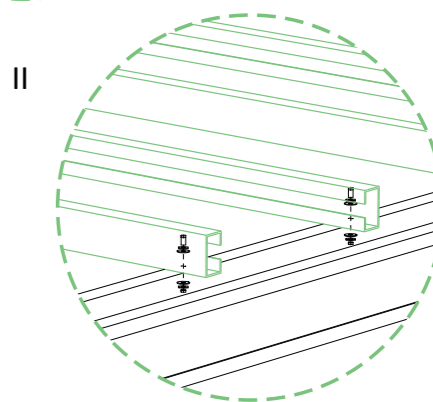
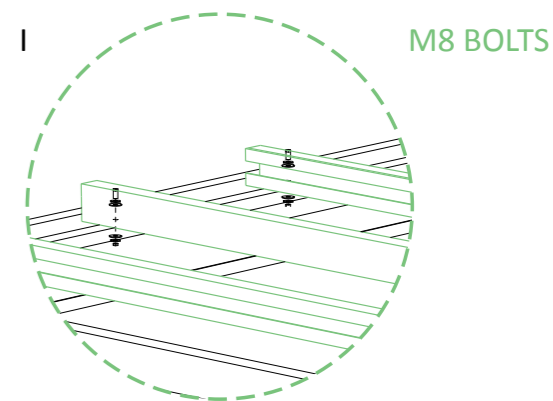

12 x J



TWO CEILING JOISTS AND LATERAL CEILING BRACE

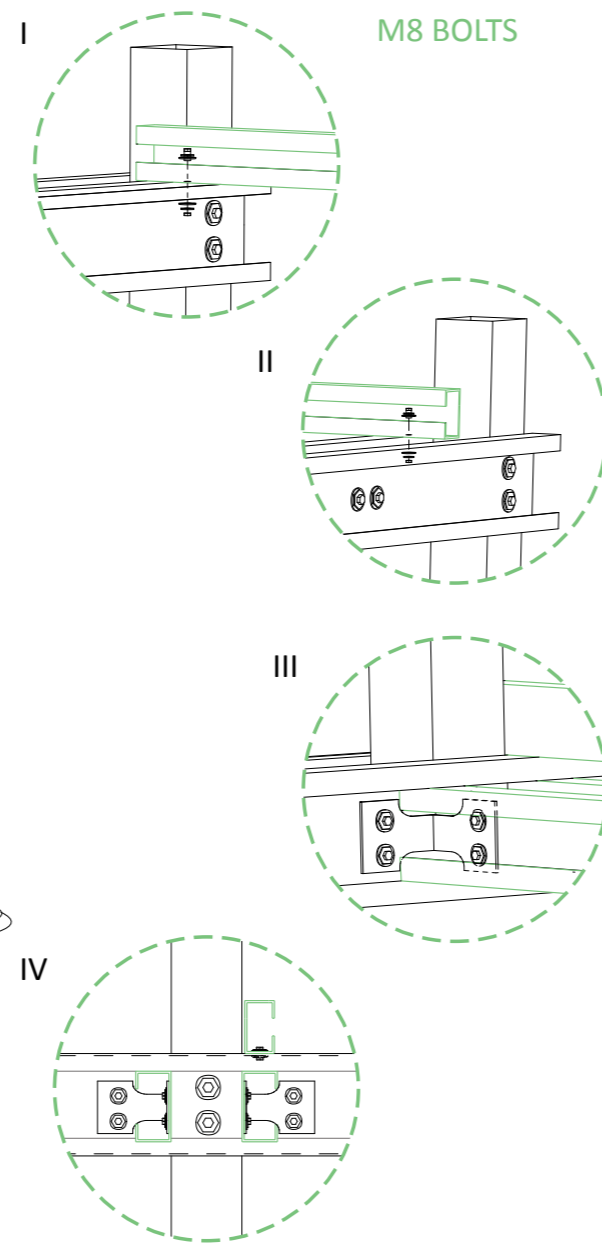
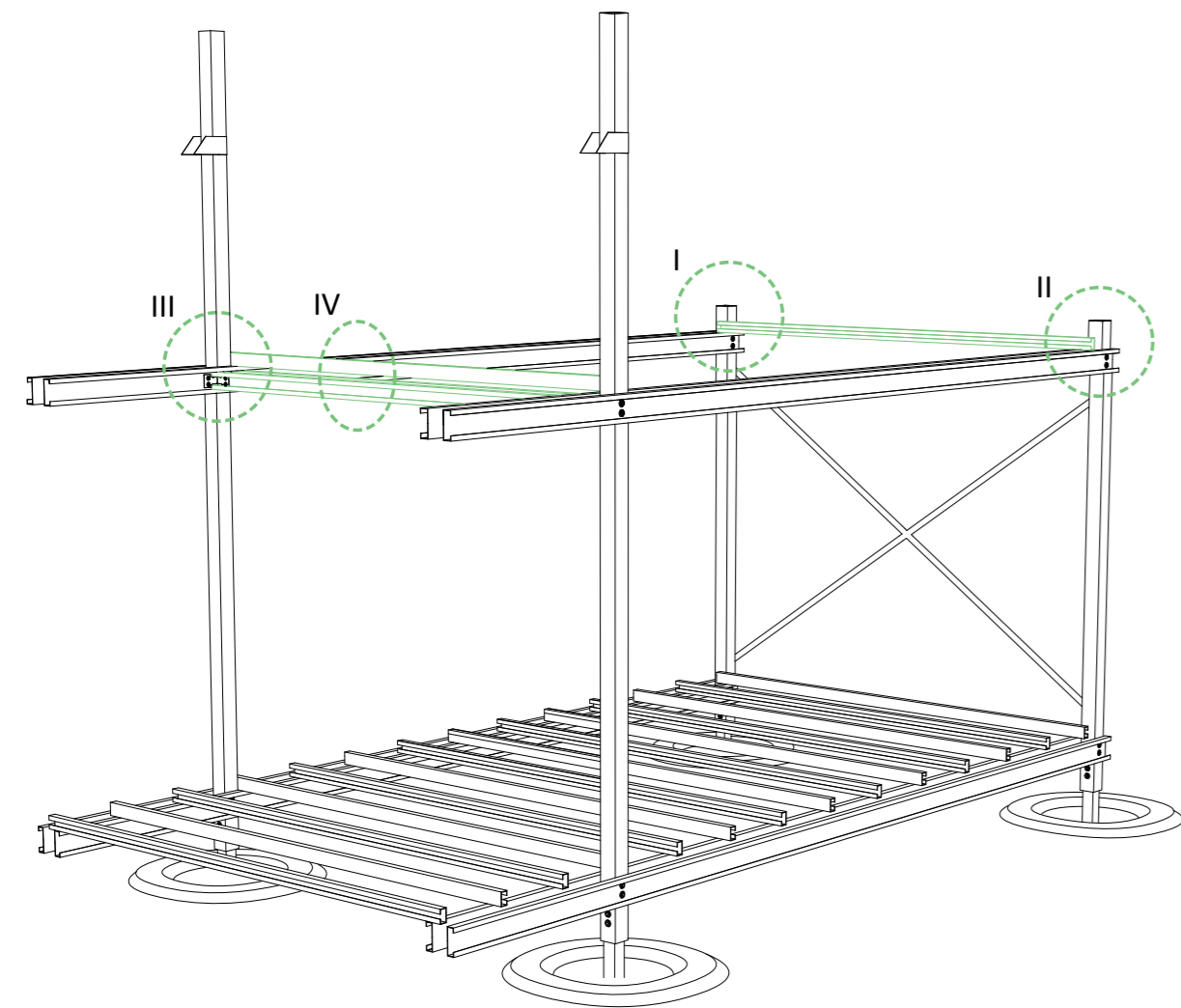

M8 BOLTS

2 x J
1 x RP

1. USE ONE M8 BOLT AT EACH END OF THE JOIST
2. REPEAT FOR 2 JOISTS
3. SECURE RP PLATES TO MC AND CB USING 4 M8 BOLTS AT EACH END



SHORT ROOF SUPPORTS

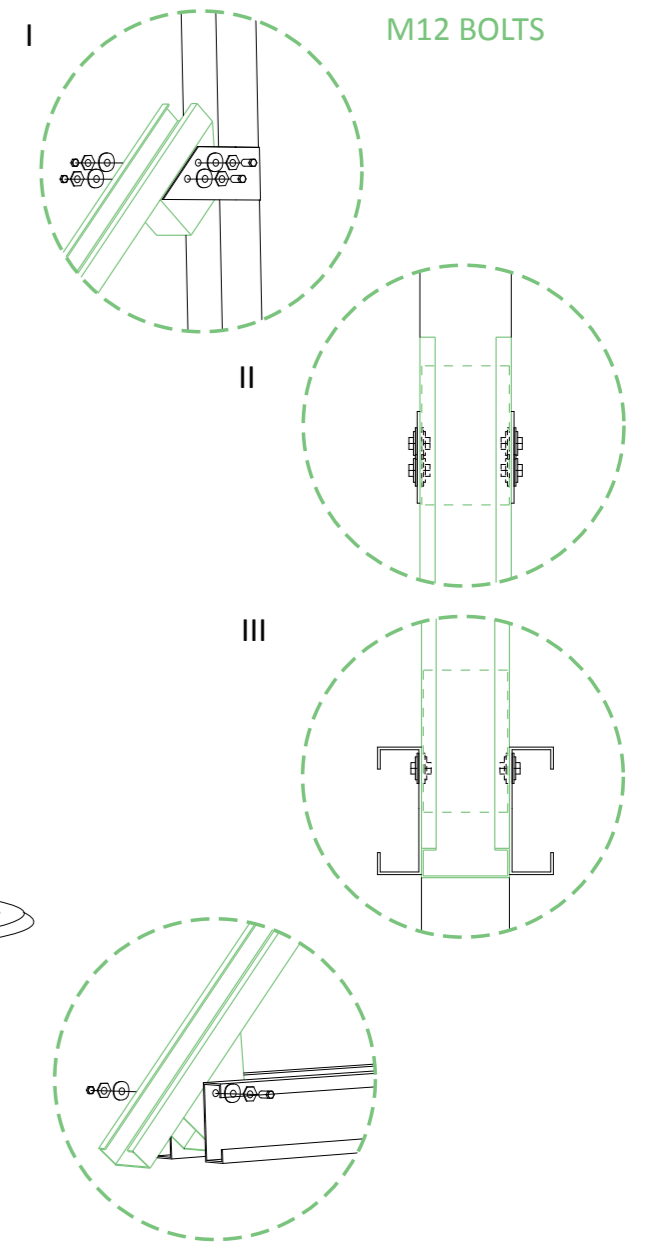
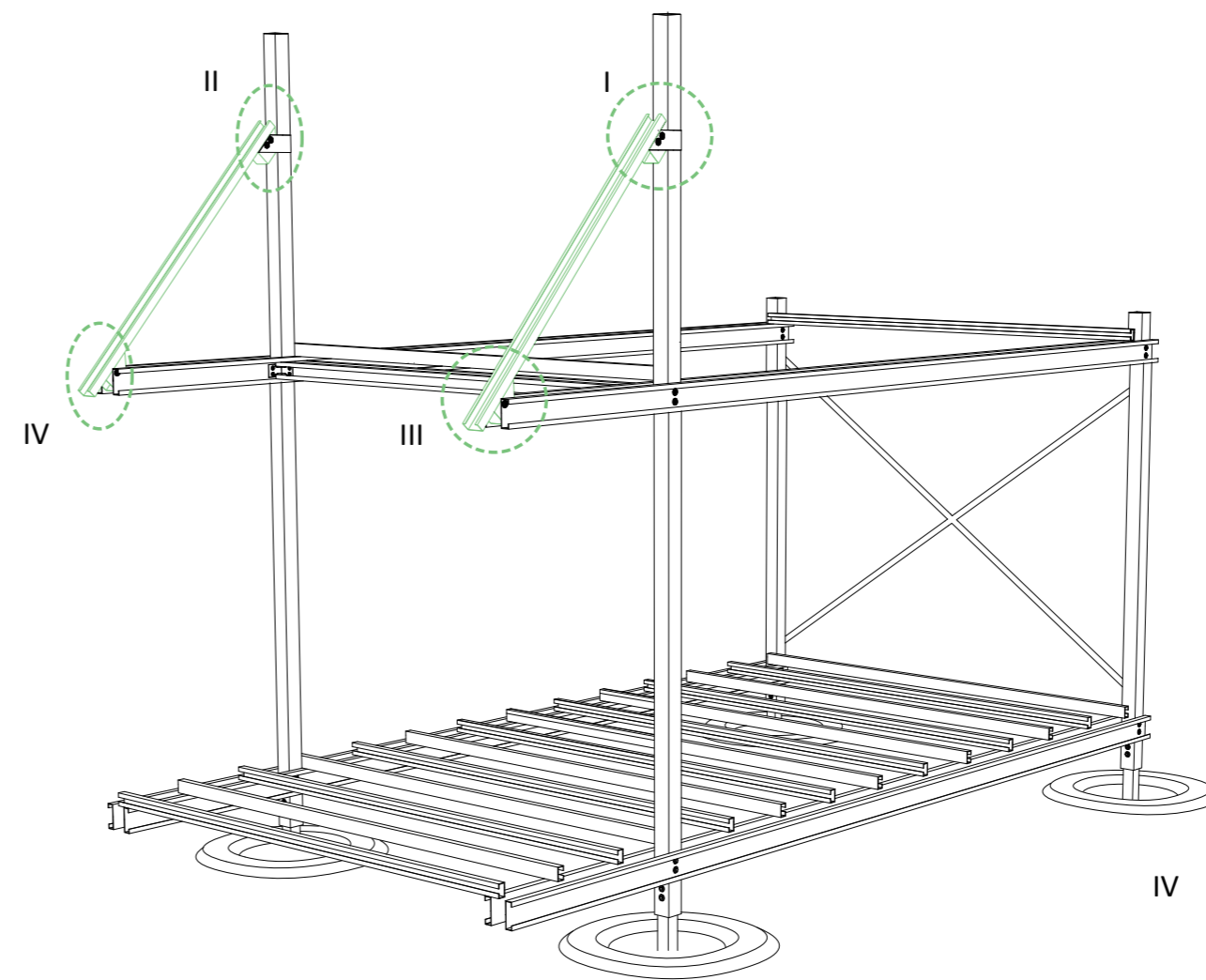

M12 BOLTS

2 x SRS

1. SECURE SRS TO MC USING 2X M12 BOLTS
SECURE SRS TO CB USING 1X M12 BOLT
2. REPEAT FOR EACH SRS



SHORT ROOF ASSEMBLY

RUBBER GASKET

PVC SHEET
(MEHLER TECHNOLOGY)

ALUMINIUM
GRIPPING STRIPS
(PROFIL TENSION SYSTEMS)

SHORT ROOF
FRAME (SRF)

RUBBER GASKET
PVC SHEET
ALUMINIUM GRIPPING STRIPS
1 x SRF

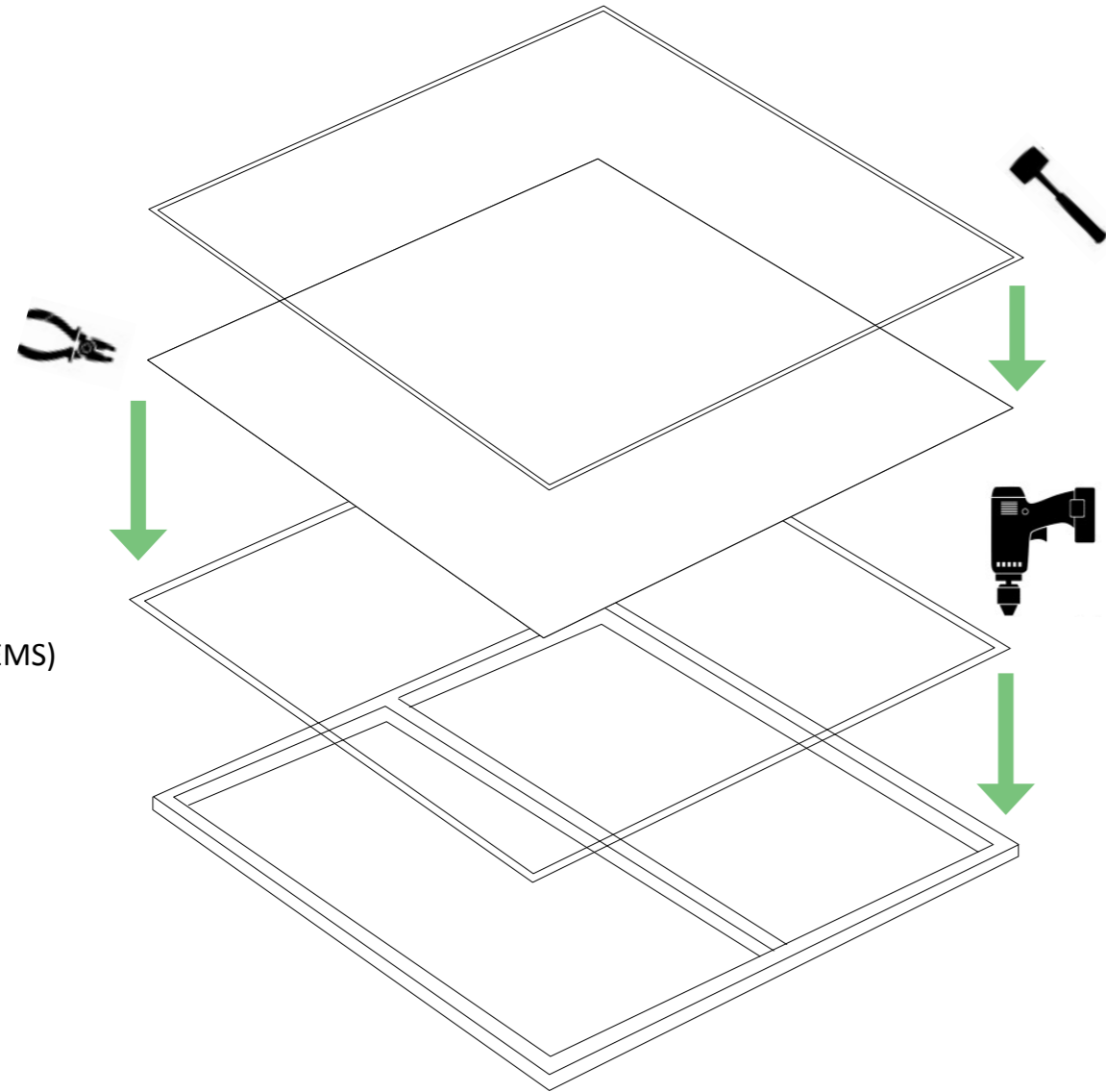

1. HAMMER IN RUBBER GASKET
TO KEEP SHEET IN PLACE

2. PLACE PVC SHEET ON TOP
WITH 100mm OVERLAP

3. SCREW ALUMINIUM STRIPS
EVERY 500mm

TIP: USE SELF-TAPPING STEEL
SCREWS, NOT ZINC-COATED, TO
NOT EFFECT ALUMINIUM STRIP



SHORT ROOF INSTALLATION

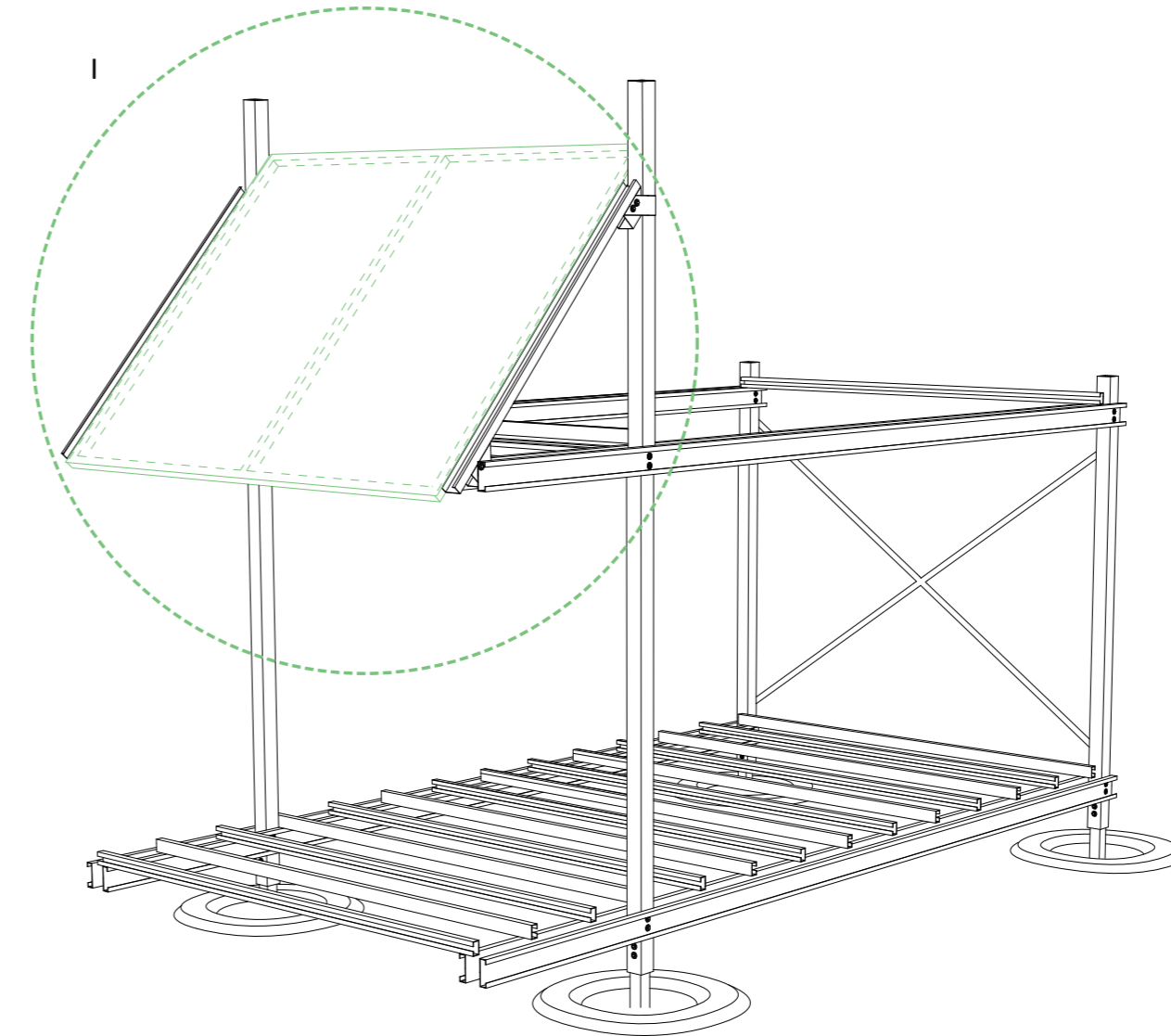

1 x ASSEMBLED SHORT ROOF

1. SECURE ASSEMBLED SHORT ROOF TO SRS'S USING ONE M8 BOLT AT EACH END
2. REPEAT FOR EACH SIDE
3. SCREW IN REMAINING SIX MIDDLE BOLTS (THREE ON EACH SIDE)

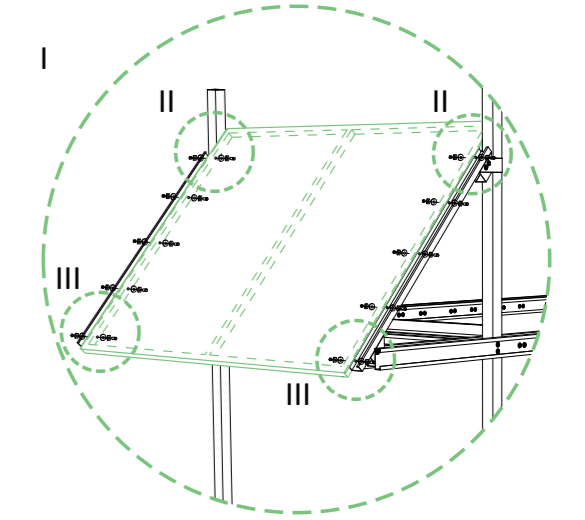

M8 BOLTS

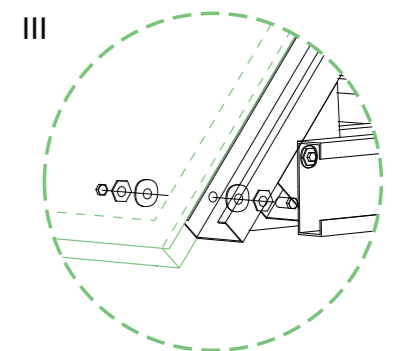
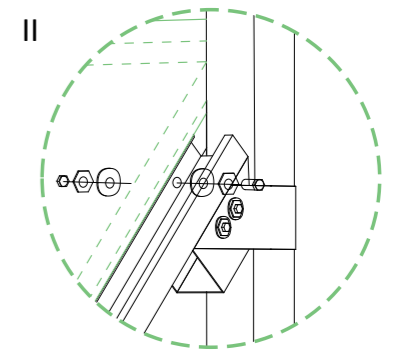

REMAINING CEILING JOISTS

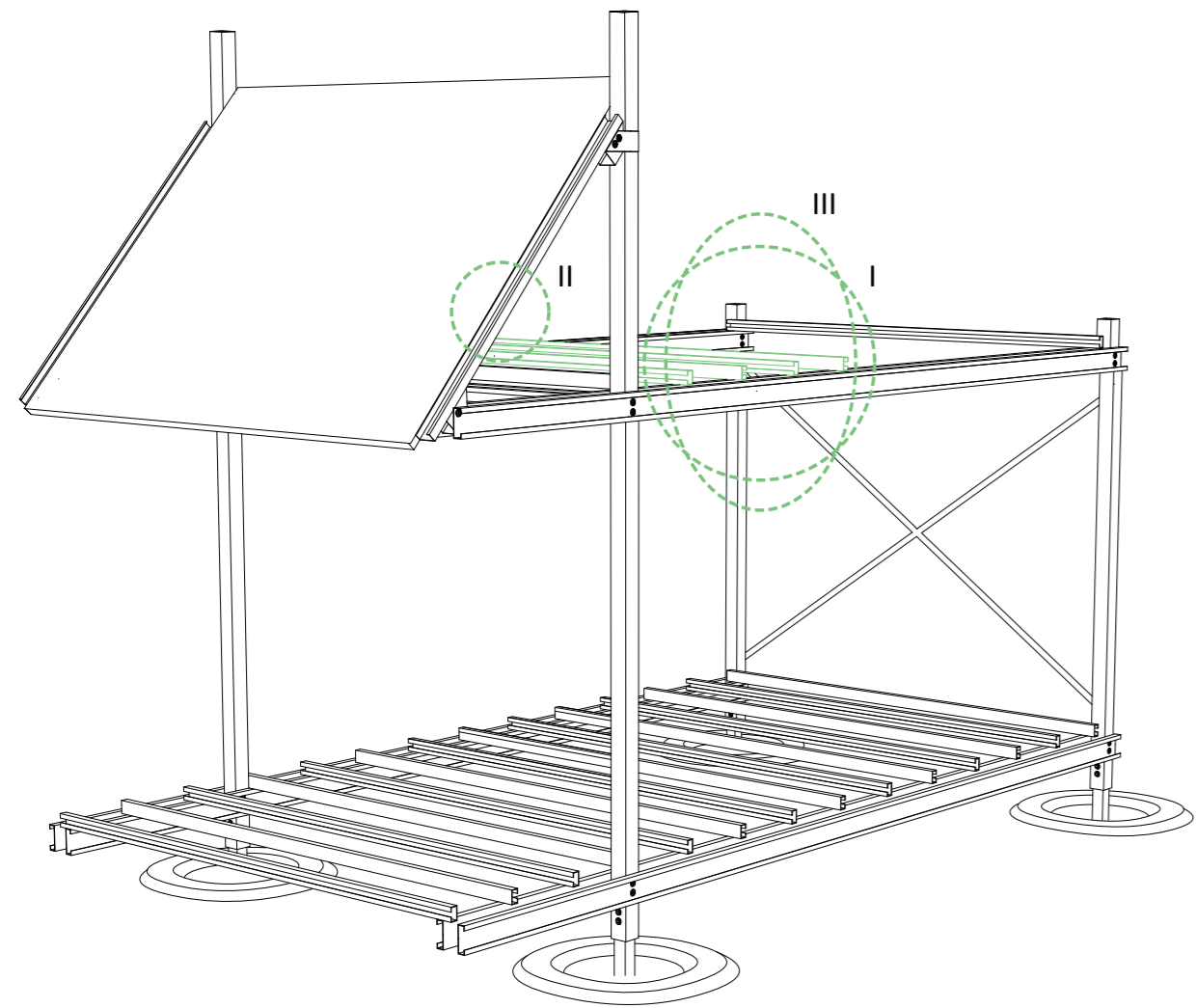

1. USE ONE M8 BOLT AT EACH END OF THE JOIST
2. ENSURE JOISTS FACE EACH OTHER (I)
3. REPEAT FOR 4 JOISTS

4 x J

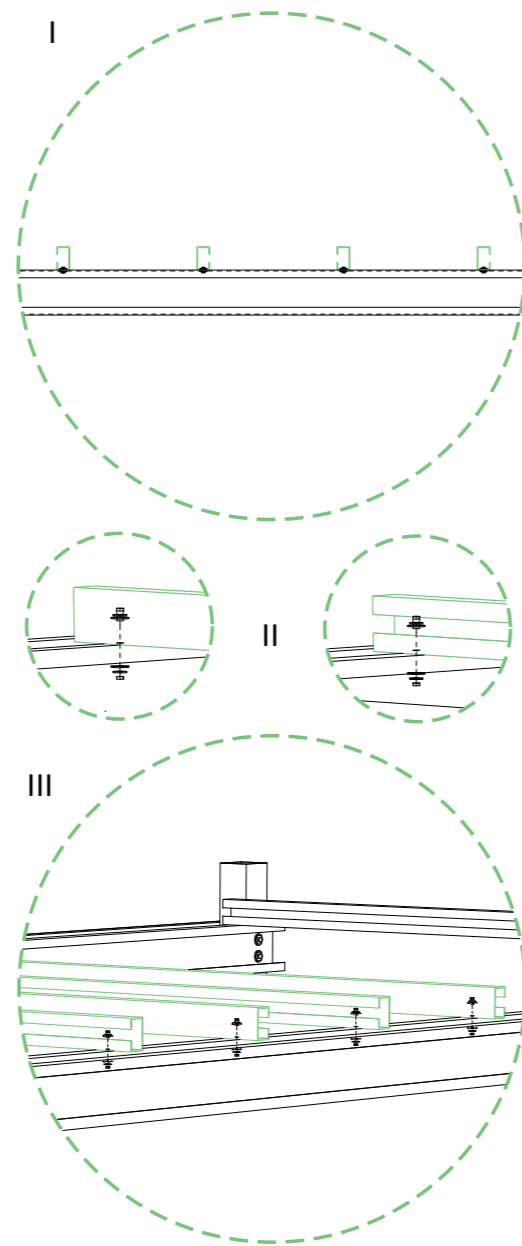

LARGE ROOF FRAME ASSEMBLY

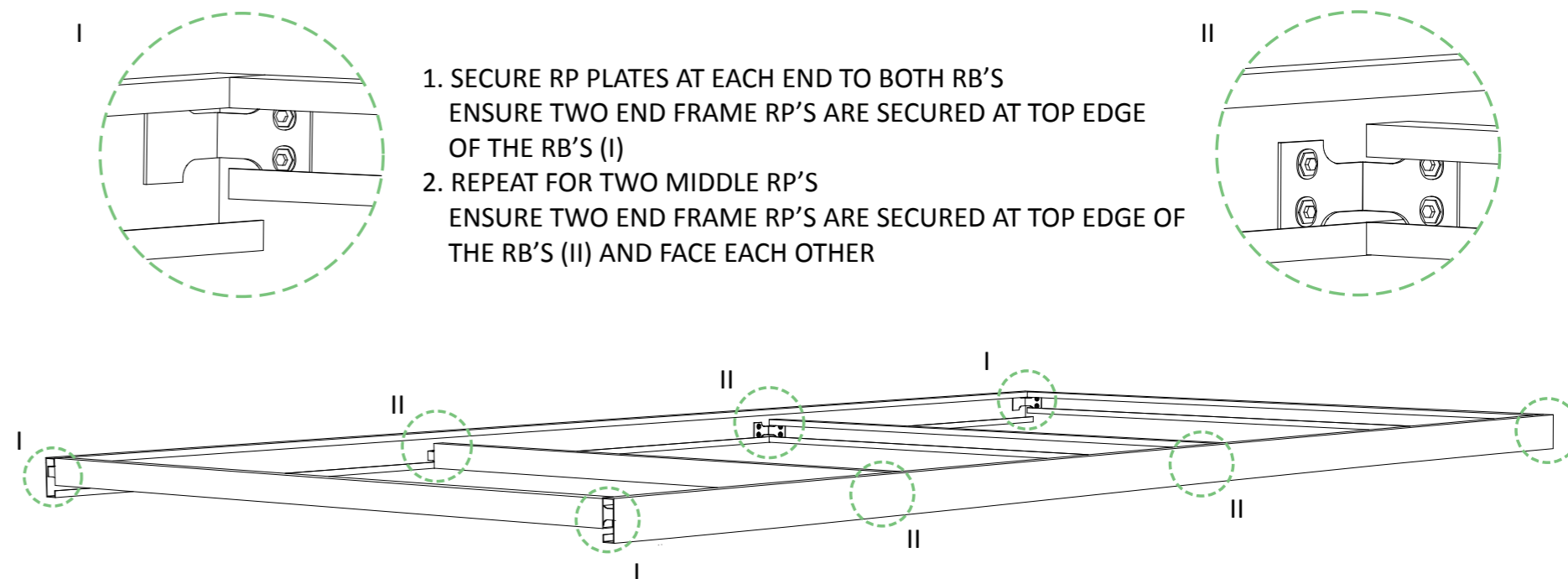
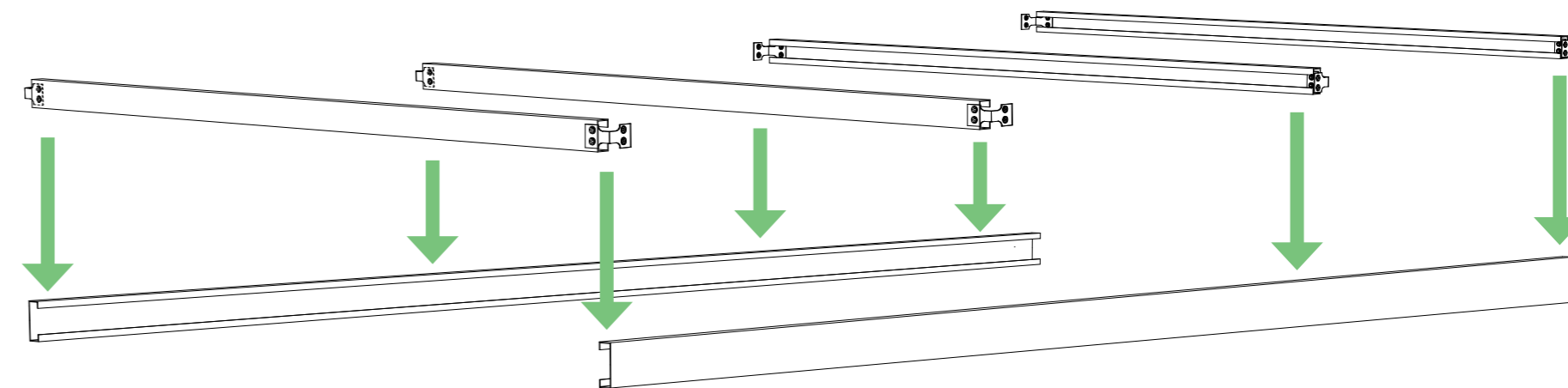

1. SECURE RP PLATES AT EACH END TO BOTH RB'S
ENSURE TWO END FRAME RP'S ARE SECURED AT TOP EDGE
OF THE RB'S (I)
2. REPEAT FOR TWO MIDDLE RP'S
ENSURE TWO END FRAME RP'S ARE SECURED AT TOP EDGE OF
THE RB'S (II) AND FACE EACH OTHER

2 x RB
4 x RP

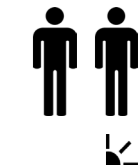

LARGE ROOF ASSEMBLY

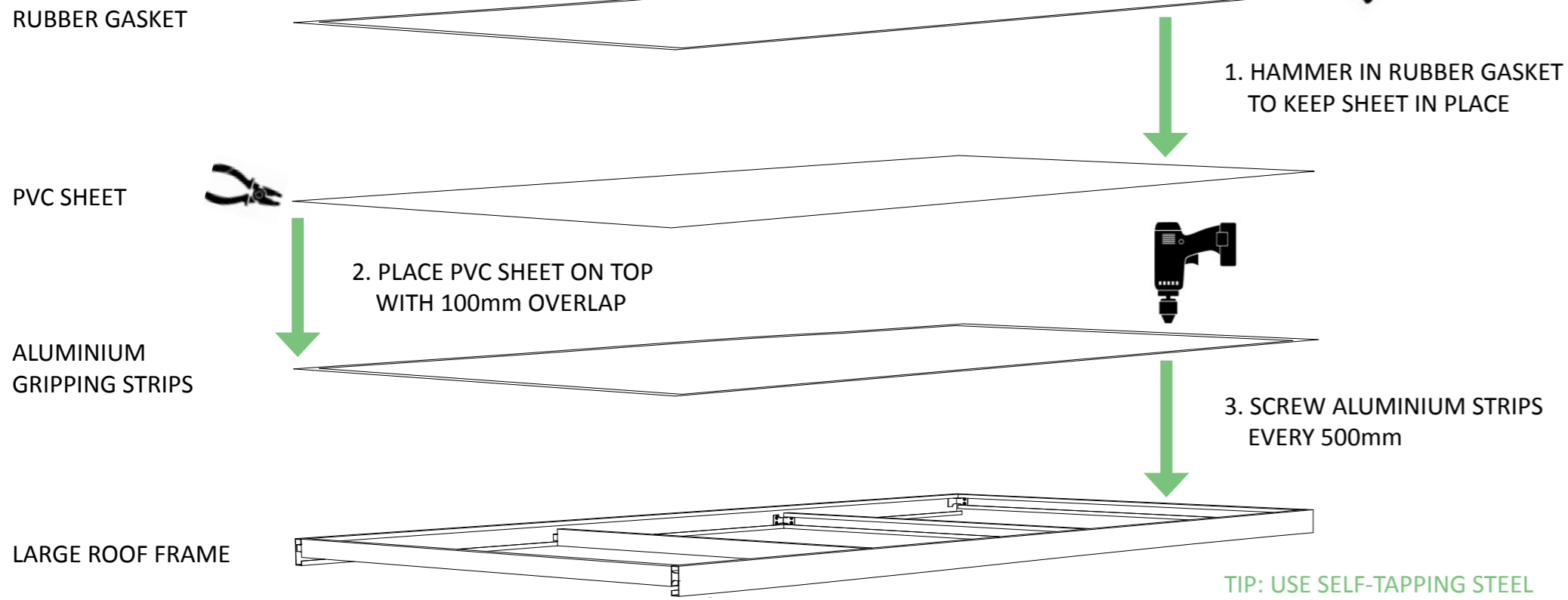
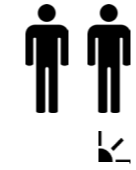

- RUBBER GASKET
- PVC SHEET
- ALUMINIUM GRIPPING STRIPS
- LARGE ROOF FRAME

TIP: USE SELF-TAPPING STEEL SCREWS, NOT ZINC-COATED, TO NOT EFFECT ALUMINIUM STRIP



LARGE ROOF ASSEMBLY - TENSION RODS

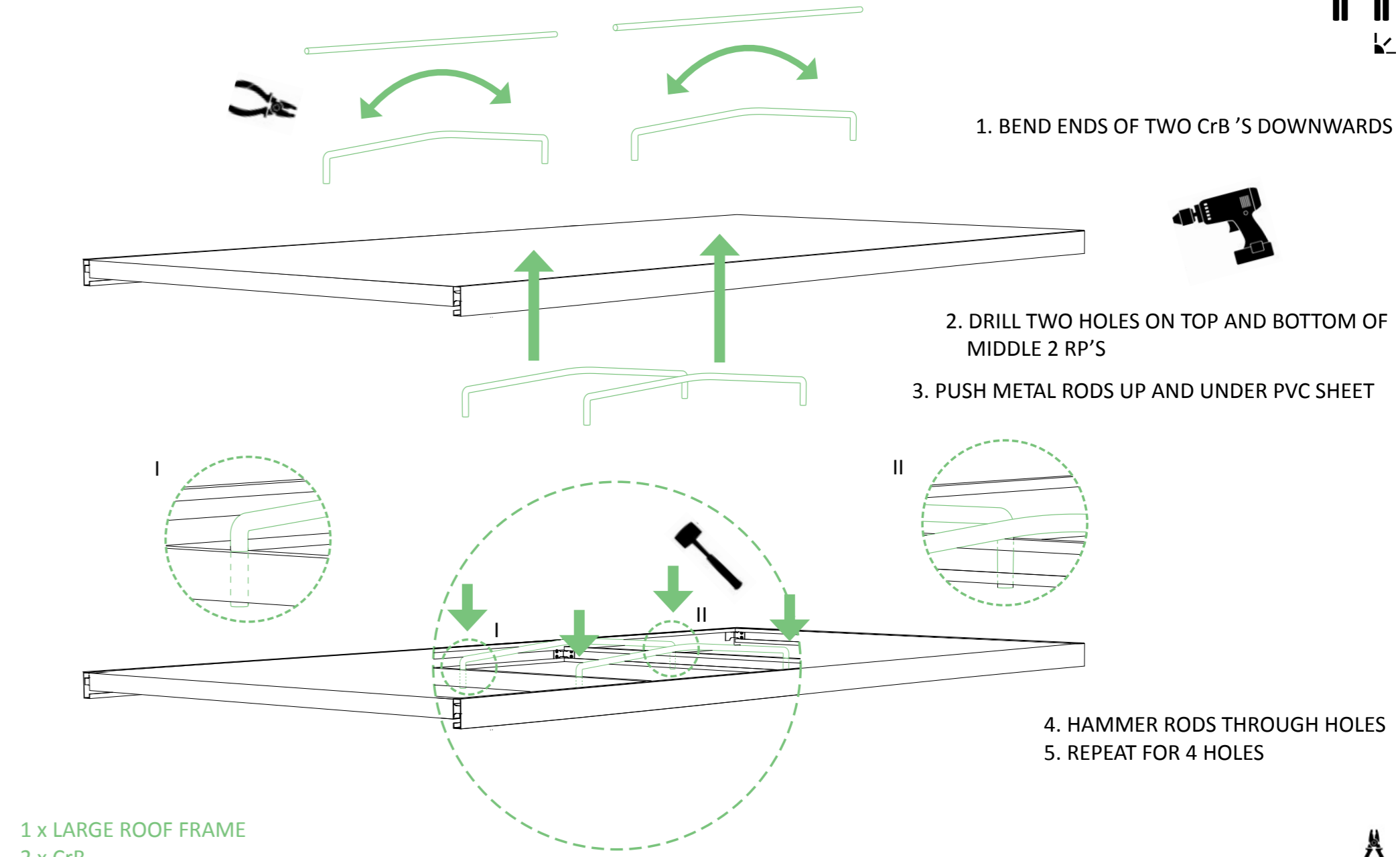
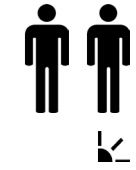

- 1 x LARGE ROOF FRAME
- 2 x CrB



LARGE ROOF INSTALLATION

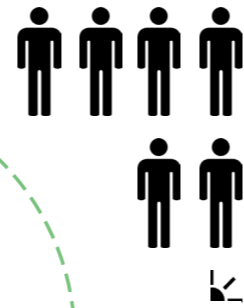
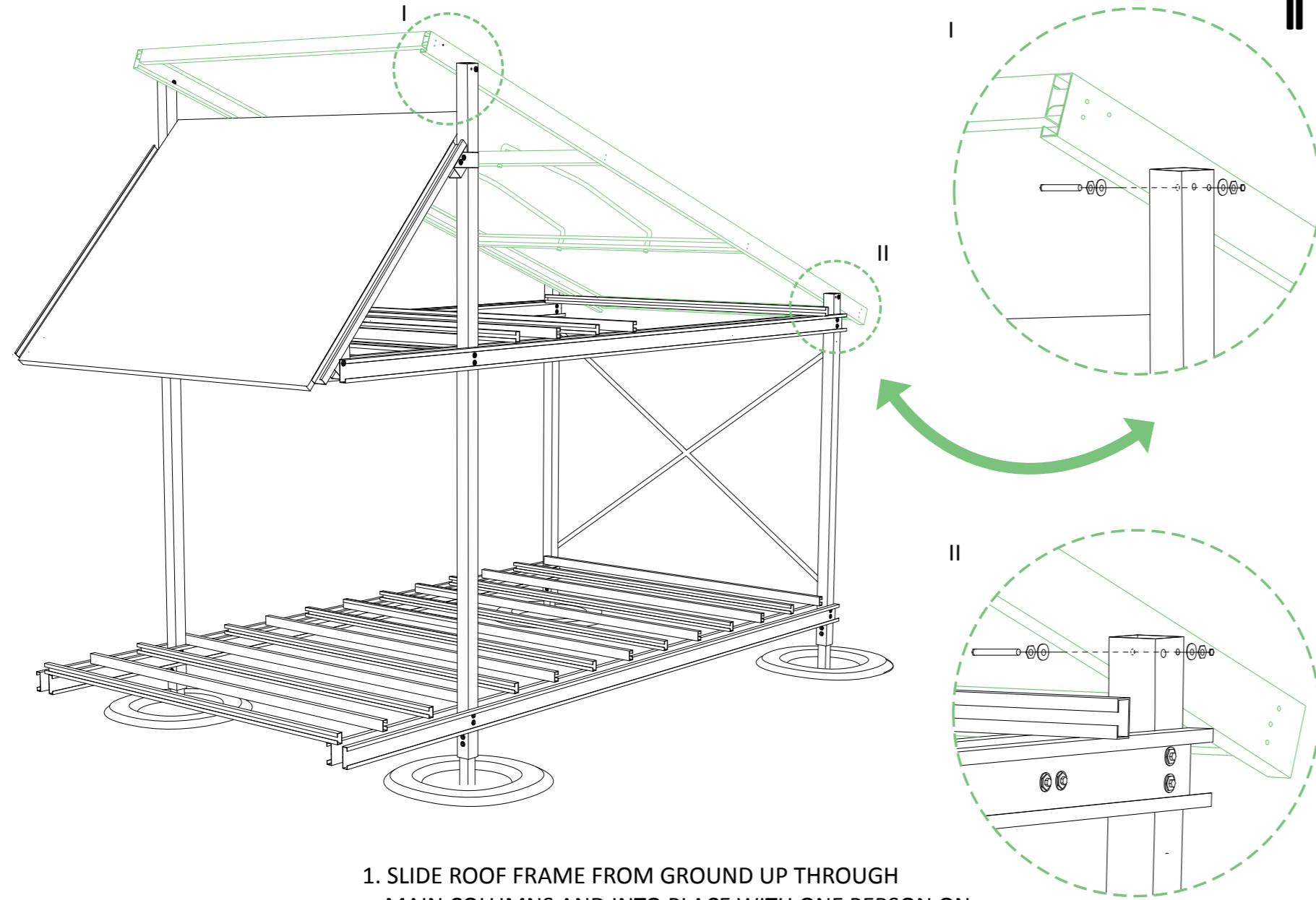

1. SLIDE ROOF FRAME FROM GROUND UP THROUGH MAIN COLUMNS AND INTO PLACE WITH ONE PERSON ON EACH COLUMN AND TWO PUSHING FROM GROUND LEVEL

1 x FULLY ASSEMBLED ROOF FRAME



FLOOR INSTALLATION

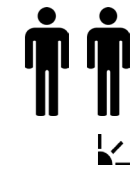
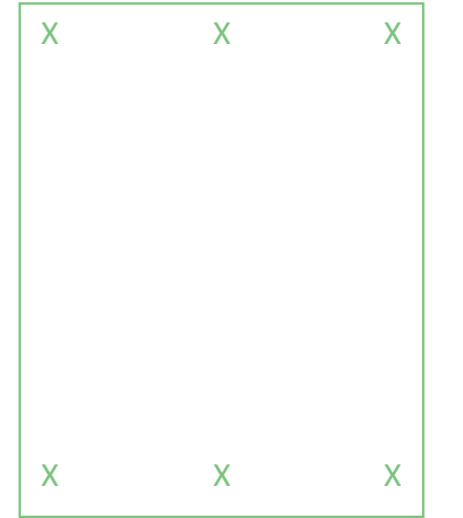
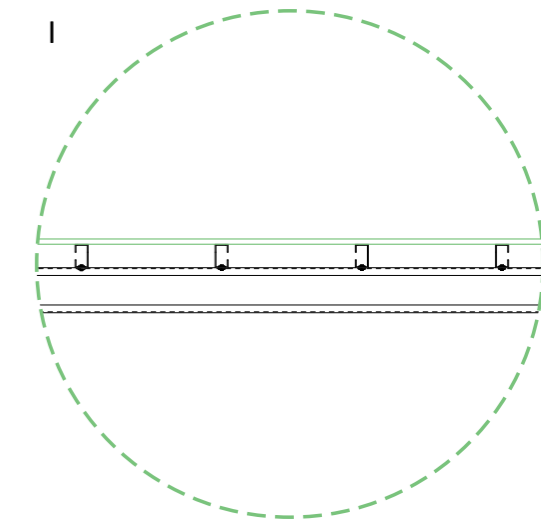
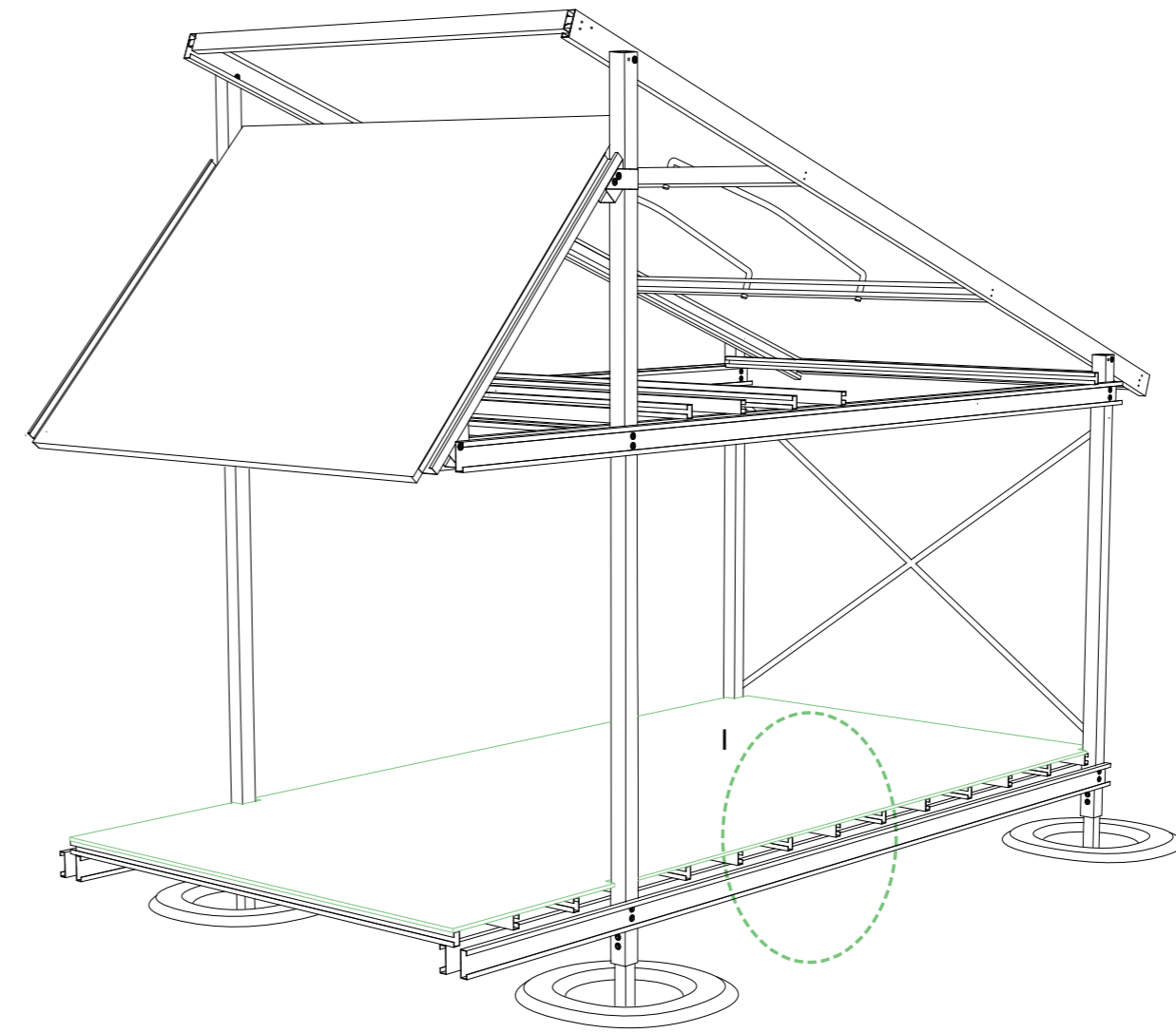

1 BAY = 6.5 SHEETS

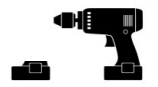

TIMBER RUNNERS FOR WALLS AND DOORS

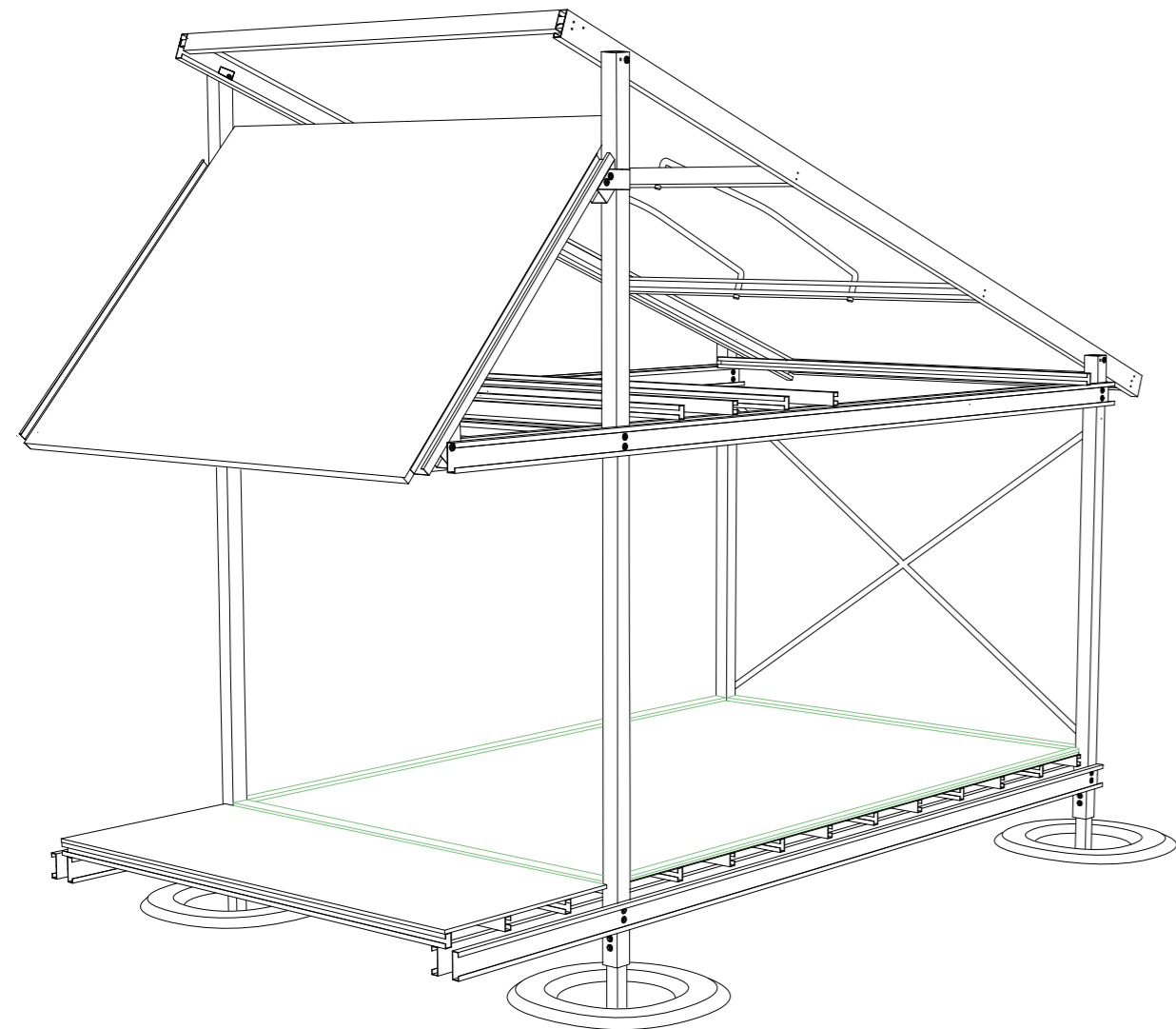

1. SCREW DOWN TIMBER RUNNERS ALONG PERIMETER CONNECTING ALL COLUMNS

4 x 20mm x 10mm TIMBERS

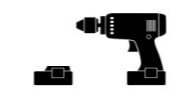

CREATE WALLS AND DOORS

ROTATE

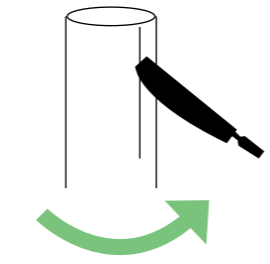

SPLIT

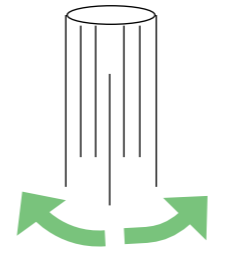

CLEAN

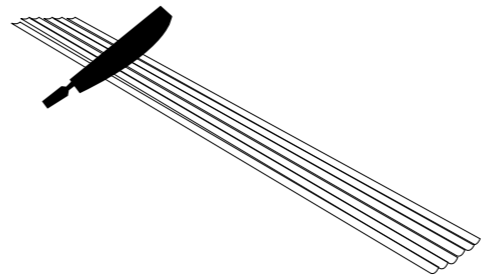

SPLIT BAMBOO

CREATE FRAME MORTICE AND TENON JOINTS + ASSEMBLE

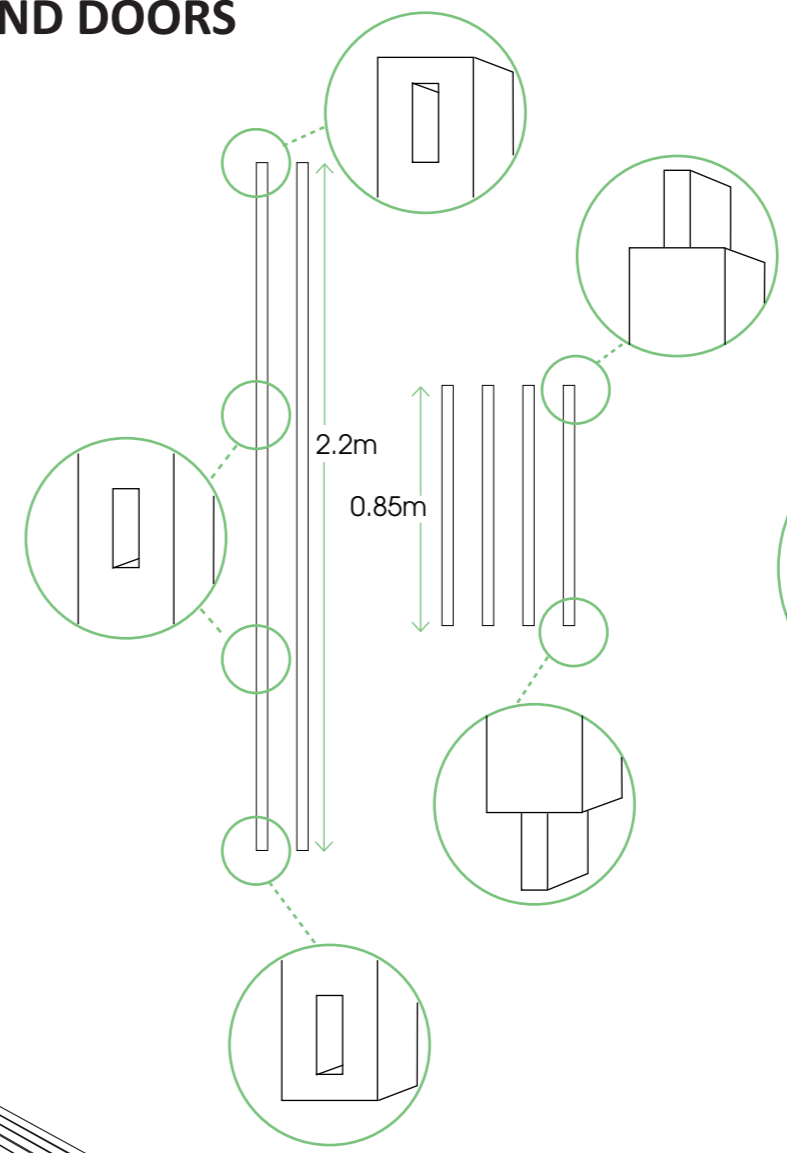

PIN BAMBOO TO FRAME

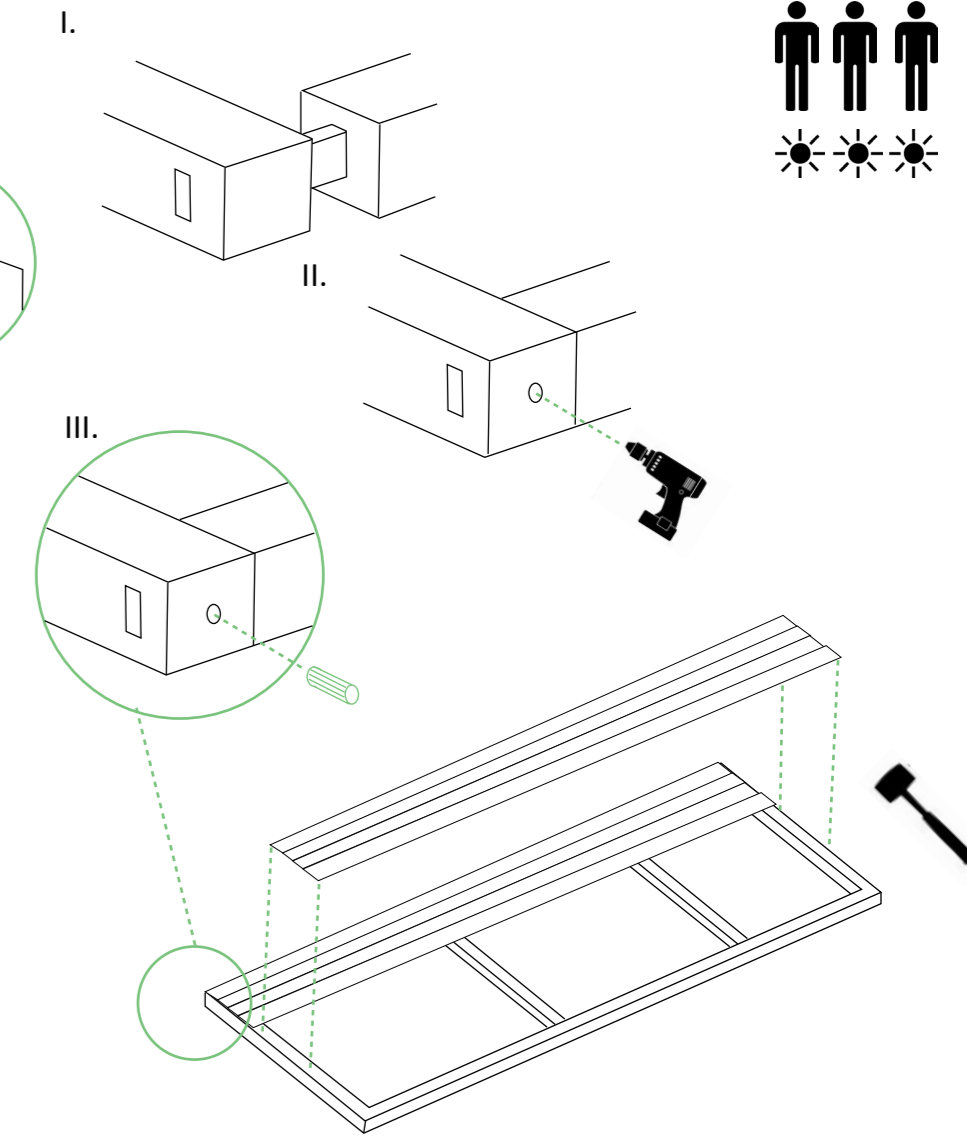

+ REPEAT

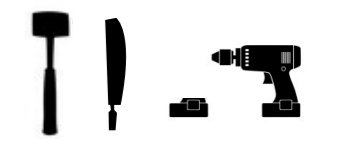

INSTALLATION OF WALLS AND BLINDS

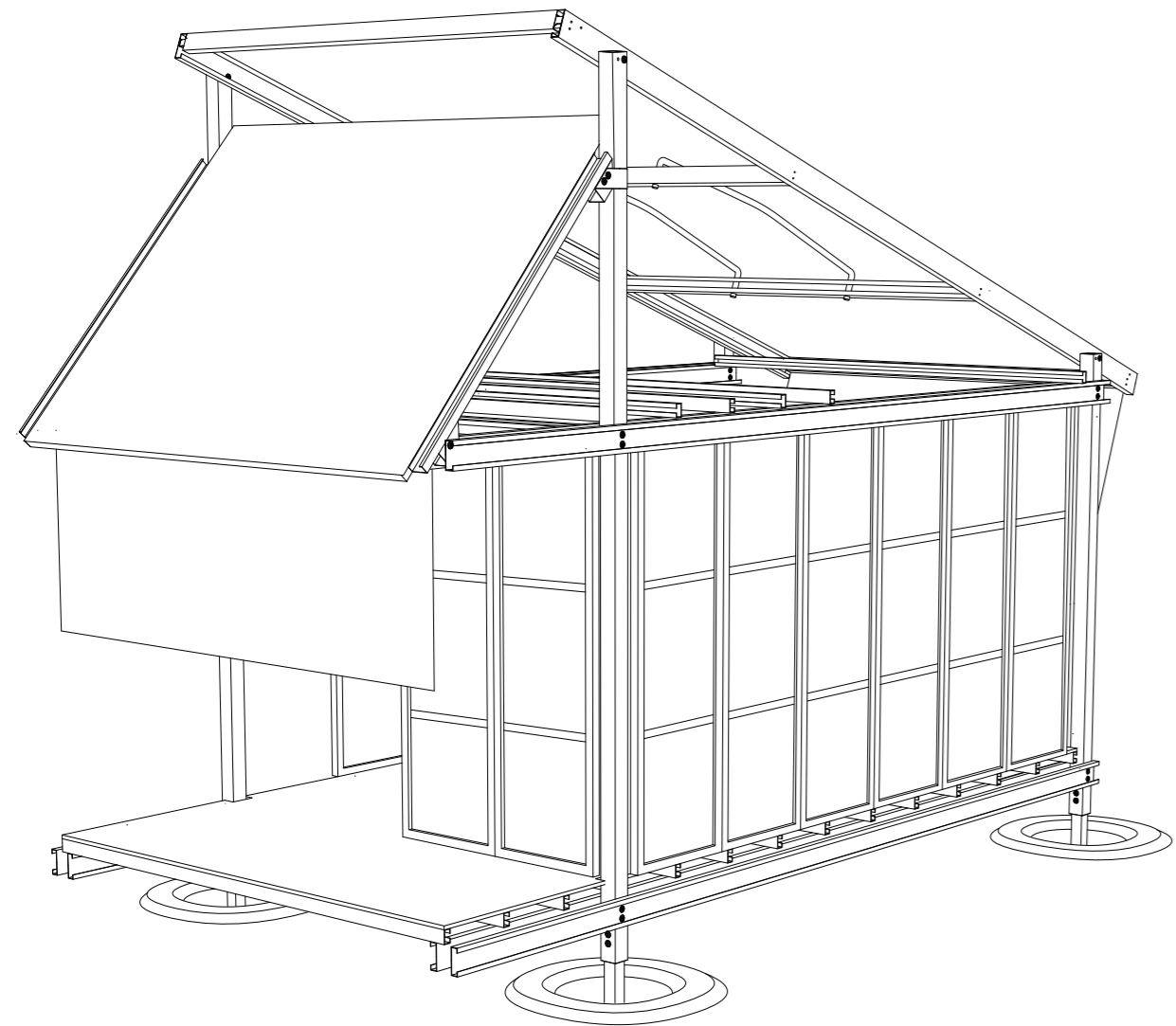

1. INFILL SIDE WALLS AND BLINDS AS DESIRED

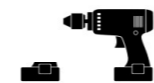

INFILL OF GABLE ENDS

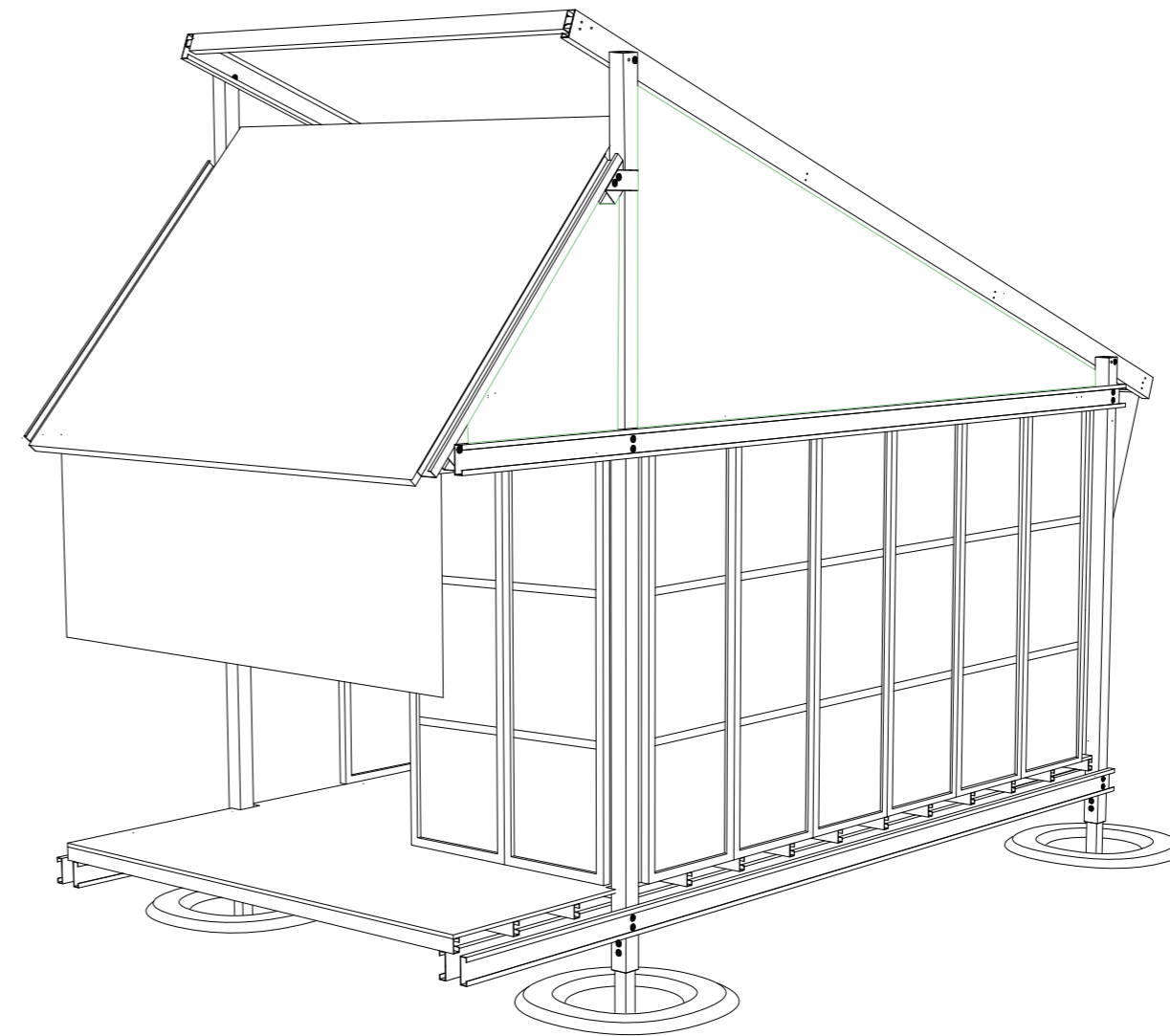

1. USE RIGID MOSQUITO MESH OR STRIPS OF BAMBOO TO INFILL GABLE ENDS

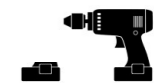

Annex 1: For repair or replacement or additional steel members please find cutting sheets for steel frame. (all measurements in mm's and drawings are not to scale.)

GB

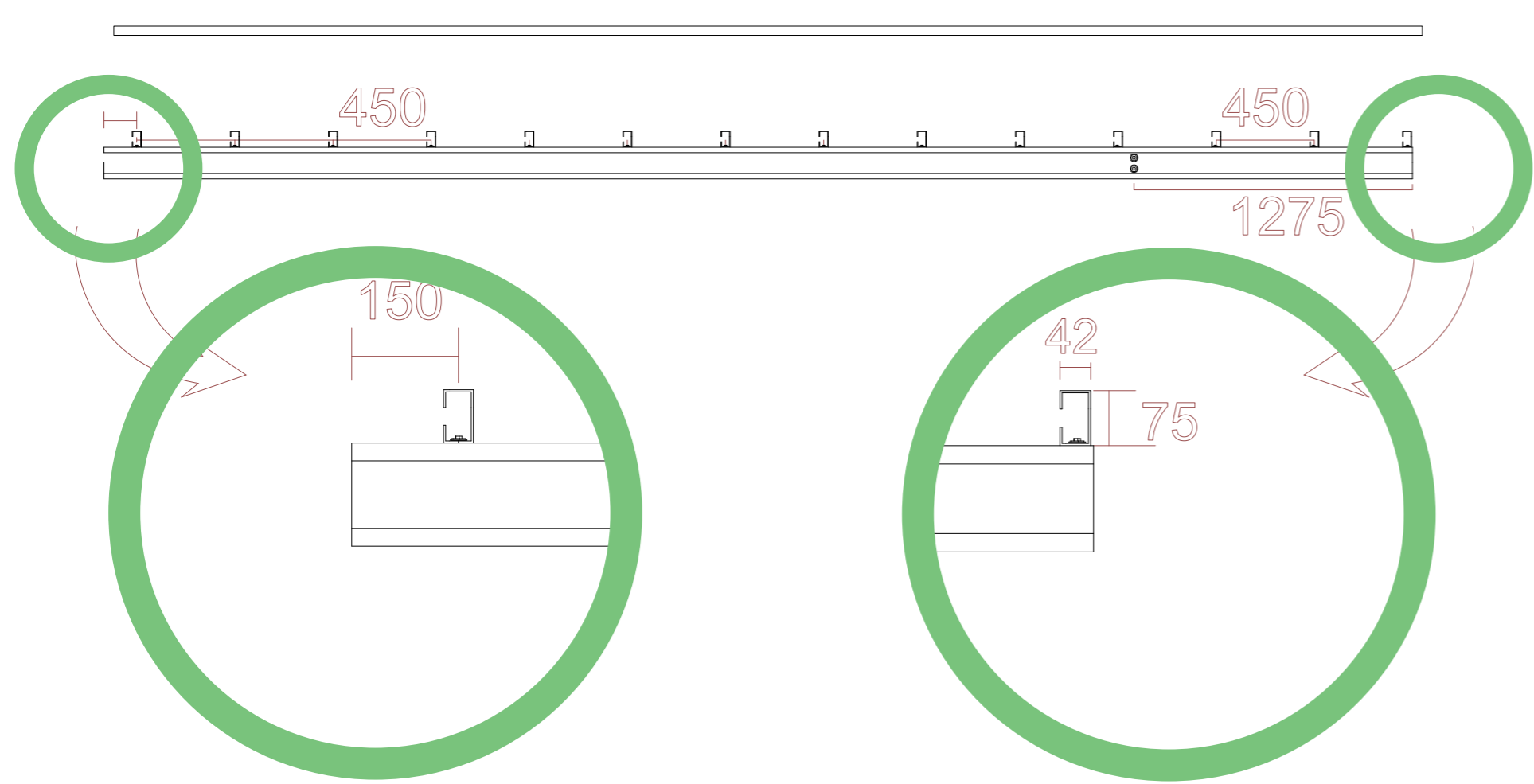

CB

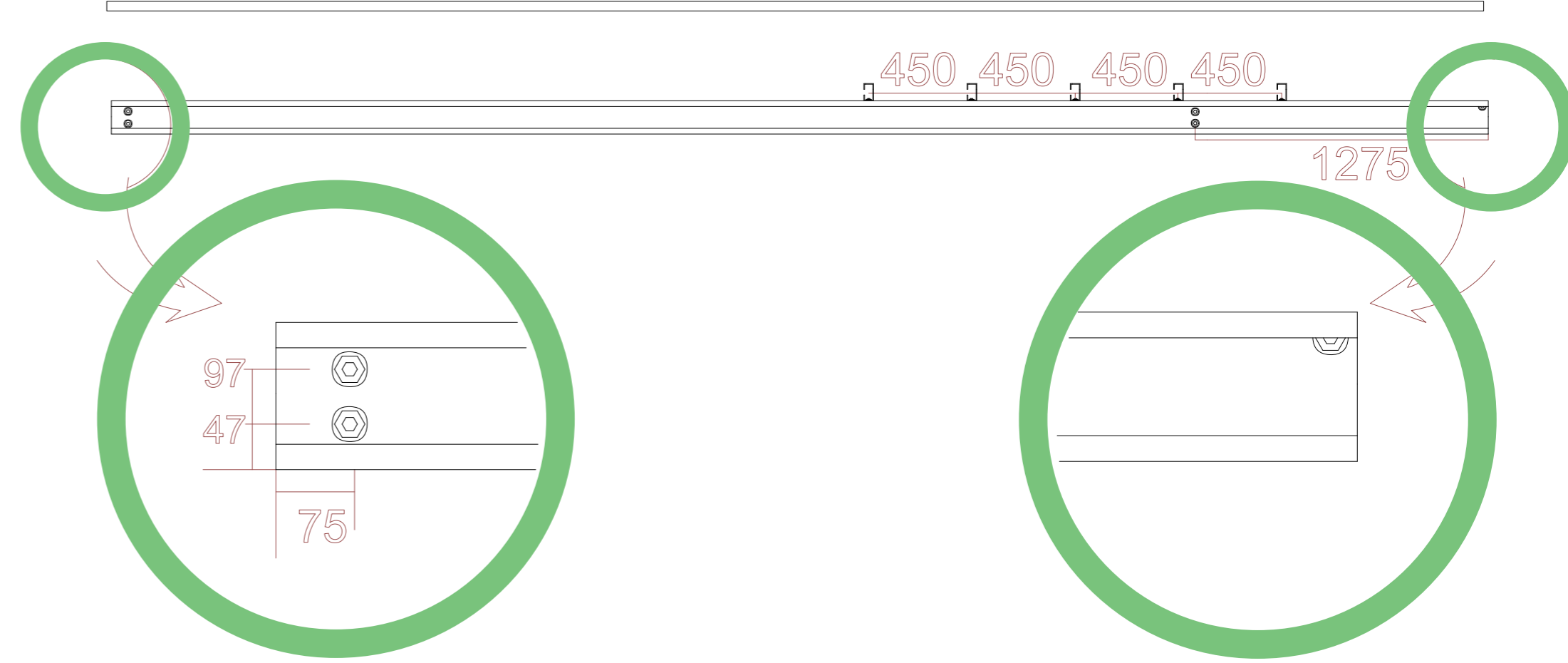

J

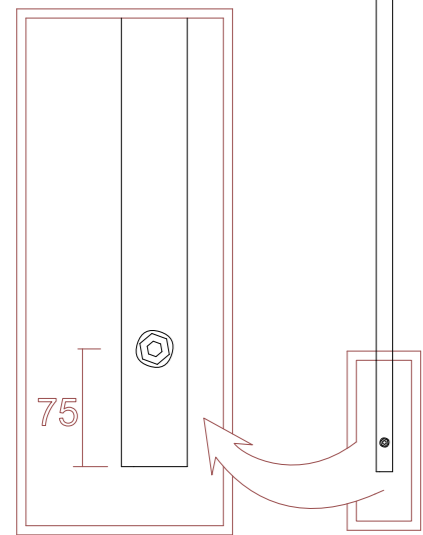
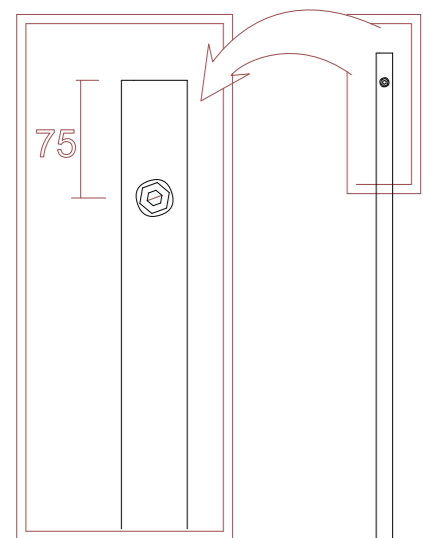

3000

RP

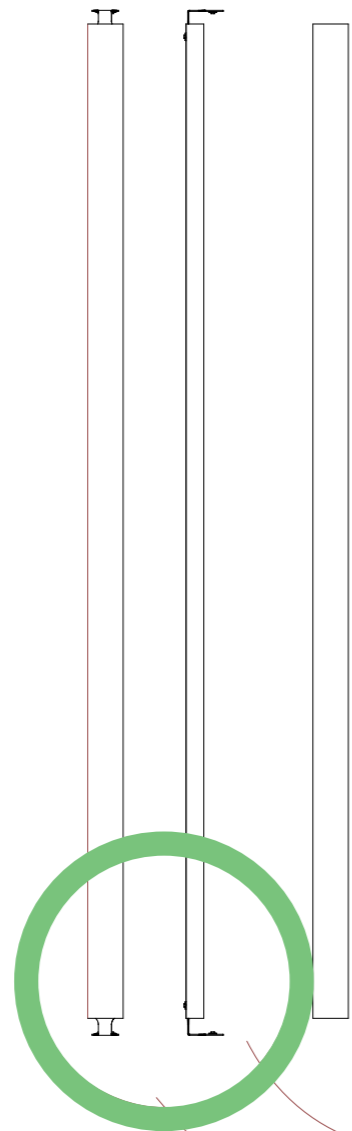

2807

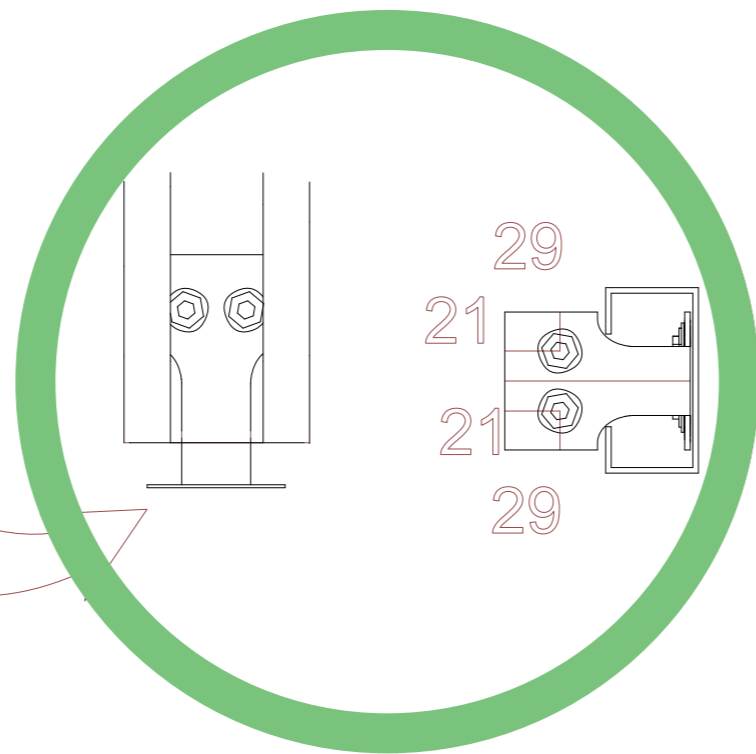

29

21

21

29

RB

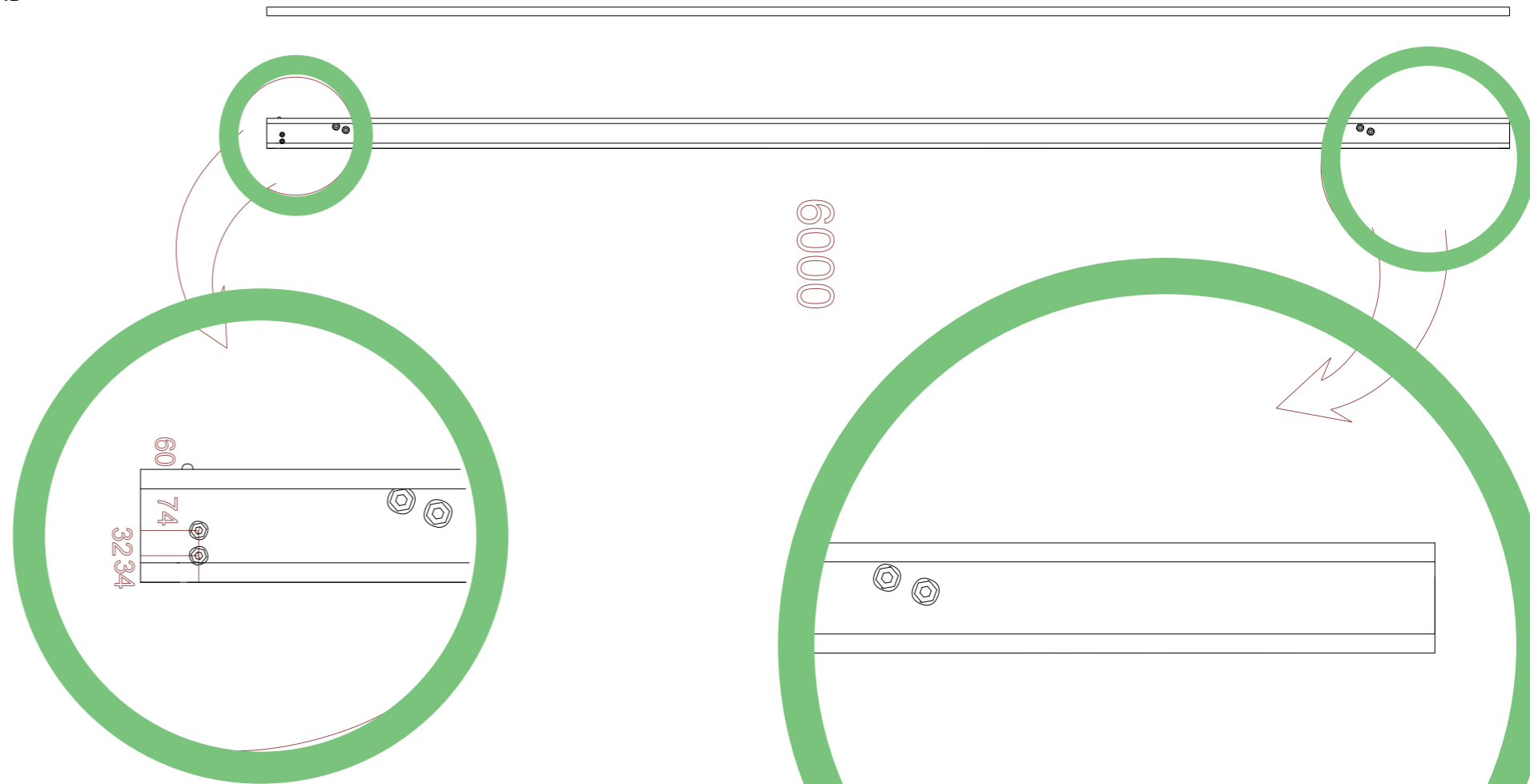

6009

60

3234

74

SRS

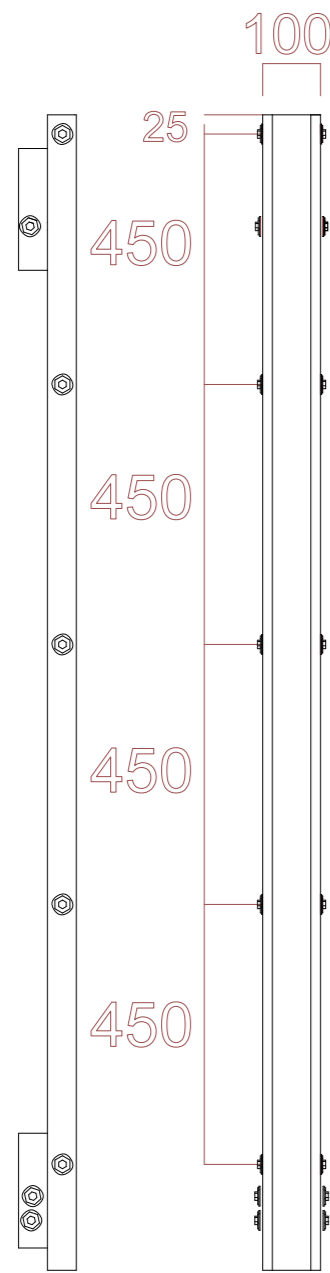
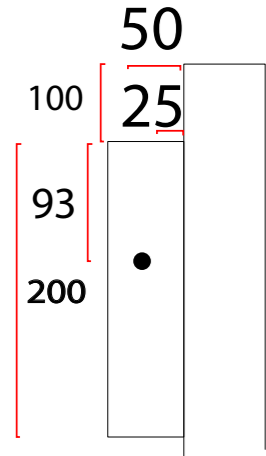

SRF

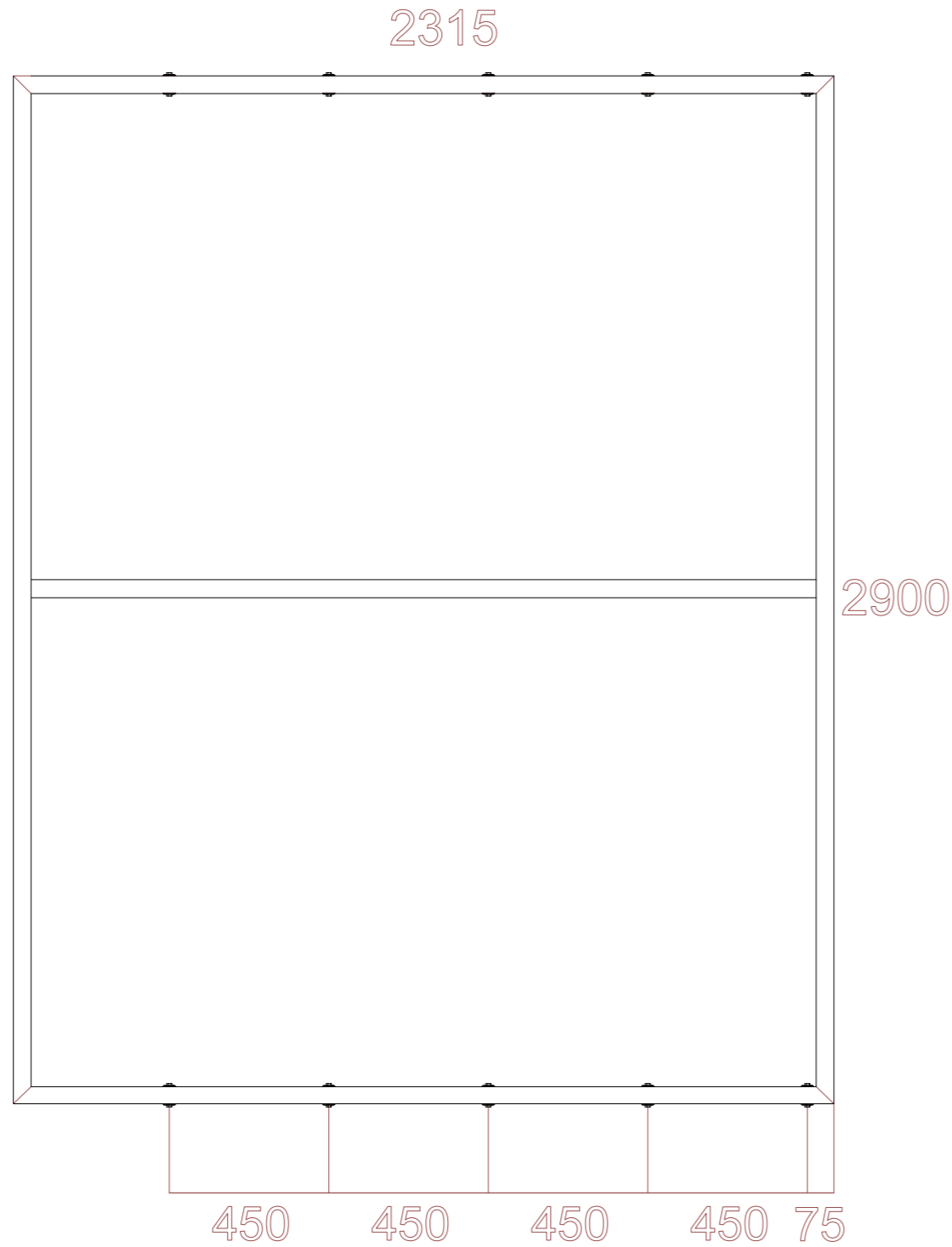

MC

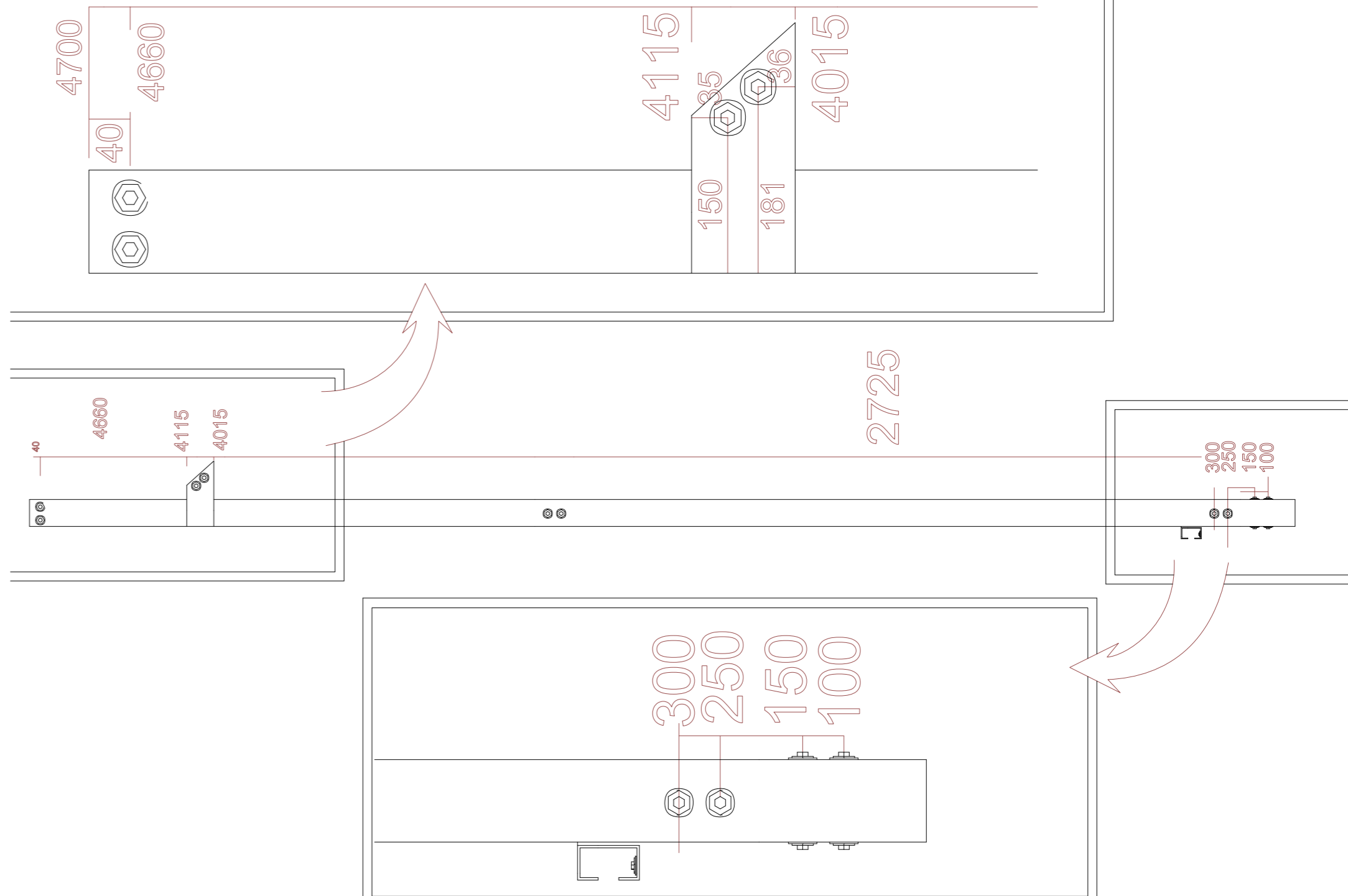

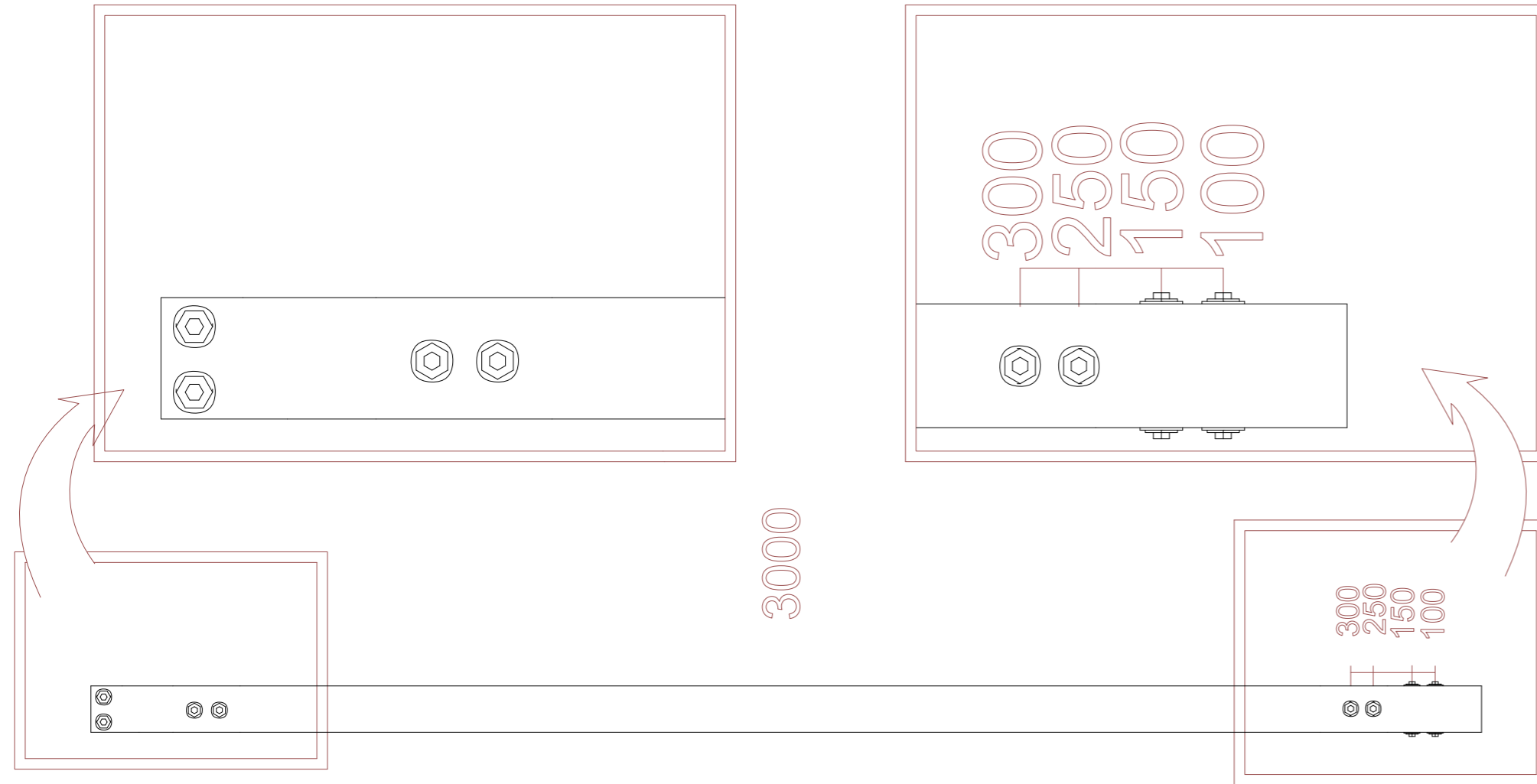

For any additional information do not hesitate to contact us;
info@buildingtrustinternational.org

Thanks

Building Trust international.