



**Charles Perkins Centre**  
University of Sydney

Photographs by  
John Gollings & Andrew Chung

# Charles Perkins Centre

University of Sydney



## Project Stats:

Address	Grose Farm Ln Camperdown NSW 2050
Start Date	2012
Completion Date	2013
GFA (m <sup>2</sup> )	49,500m <sup>2</sup>

## Quick Facts:

- The new building comprises a structure of seven floors, plus three basement levels, and an area of approximately 49,500 square metres – almost twice the surface area of the Sydney Cricket Ground.
- Catering for 950 researchers and 1,445 undergraduate and post graduate students the Charles Perkins Centre creates a new social and educational hub for the western side of the University's campus.
- Aims to improve the diagnosis and treatment of obesity, diabetes and cardiovascular disease through the provision of state-of-the-art research and education facilities.
- Close to the Royal Prince Alfred Hospital, the faculties of medicine, science and veterinary science, and the Centenary Institute, and adjacent to St John's college, the centre will cater for multidisciplinary research across biomedical sciences, bioinformatic and computational biology, and clinical research and behavioural science.







The concept of 'motion' is expressed by internal elements shifting or turning on each floor level. A reference to DNA profiling and biology, 'ribbons' are reflected by expressing key interior elements in a long linear fashion to connect circulation and interaction spaces. These ribbon elements are curved like the continuous 'flow' of blood in the cardiovascular system. Similar to the biology of the human body, these concepts form an integral design system.



A layered use of colour was essential in realising our design concept to animate the atrium – the social heart of the building – and aid legibility for such a large, open building. Colour distinguishes and articulates the curved forms of the various social/interaction spaces, meeting rooms and office clusters as well as providing an individual character for each floor.

Bold white flowing 'ribbons' of the atrium edge and staircases lead to organically shaped common spaces on each floor. Set against the crisp white is a warm colour palette that adds an expression

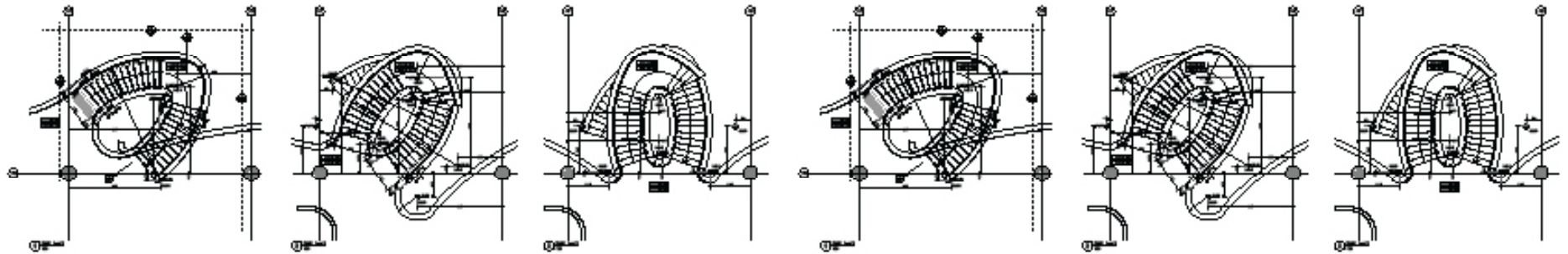
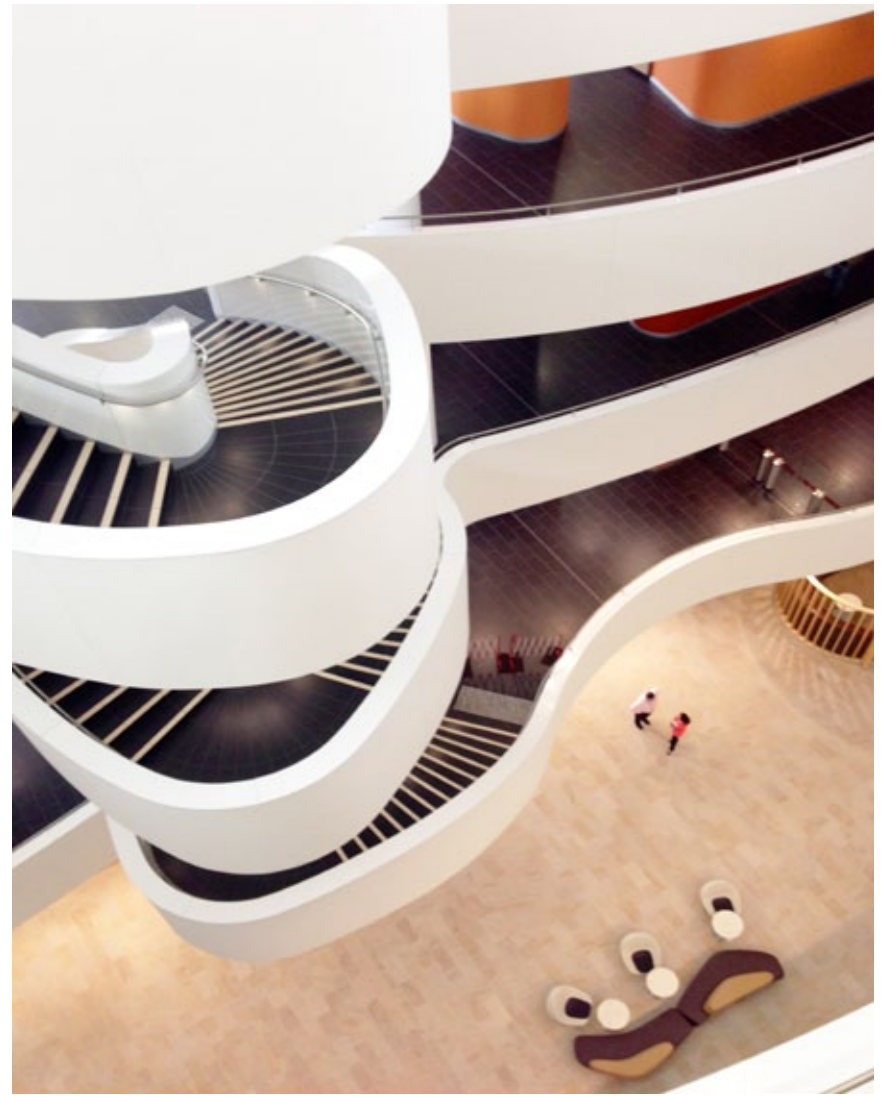
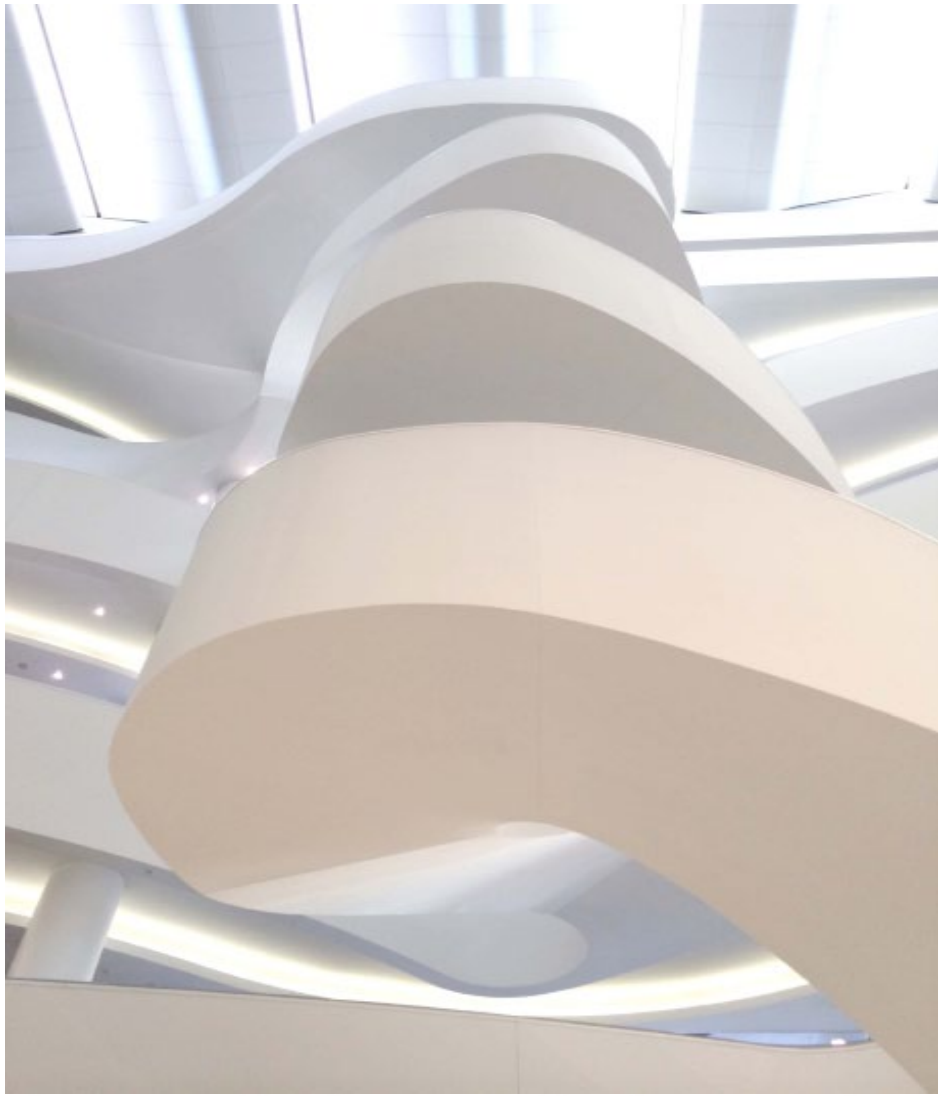

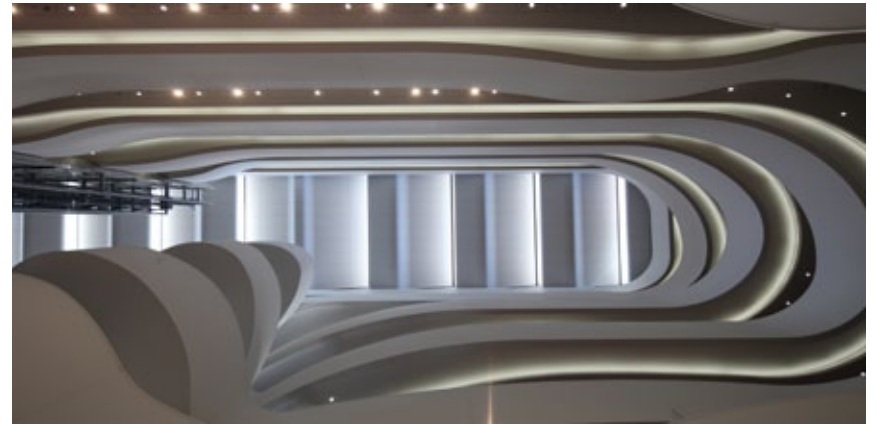
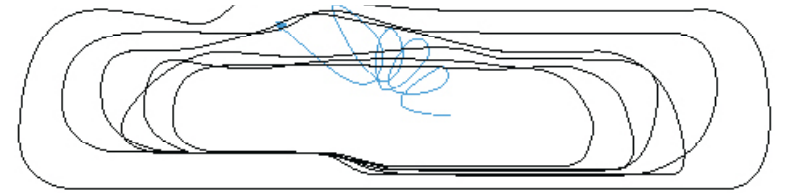

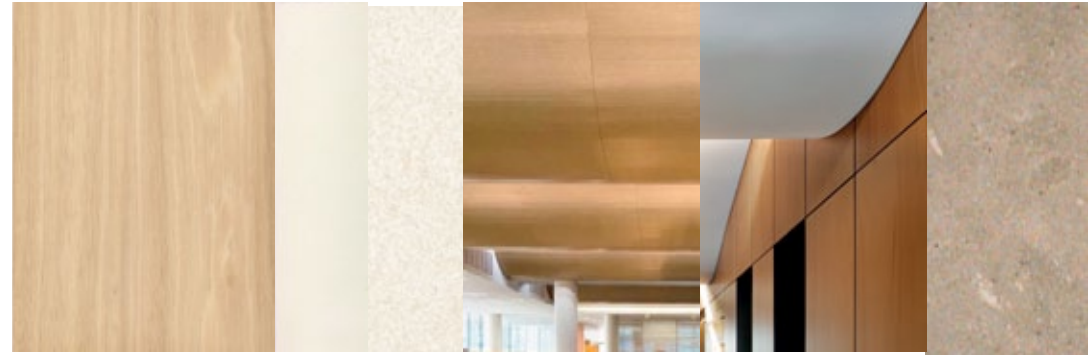









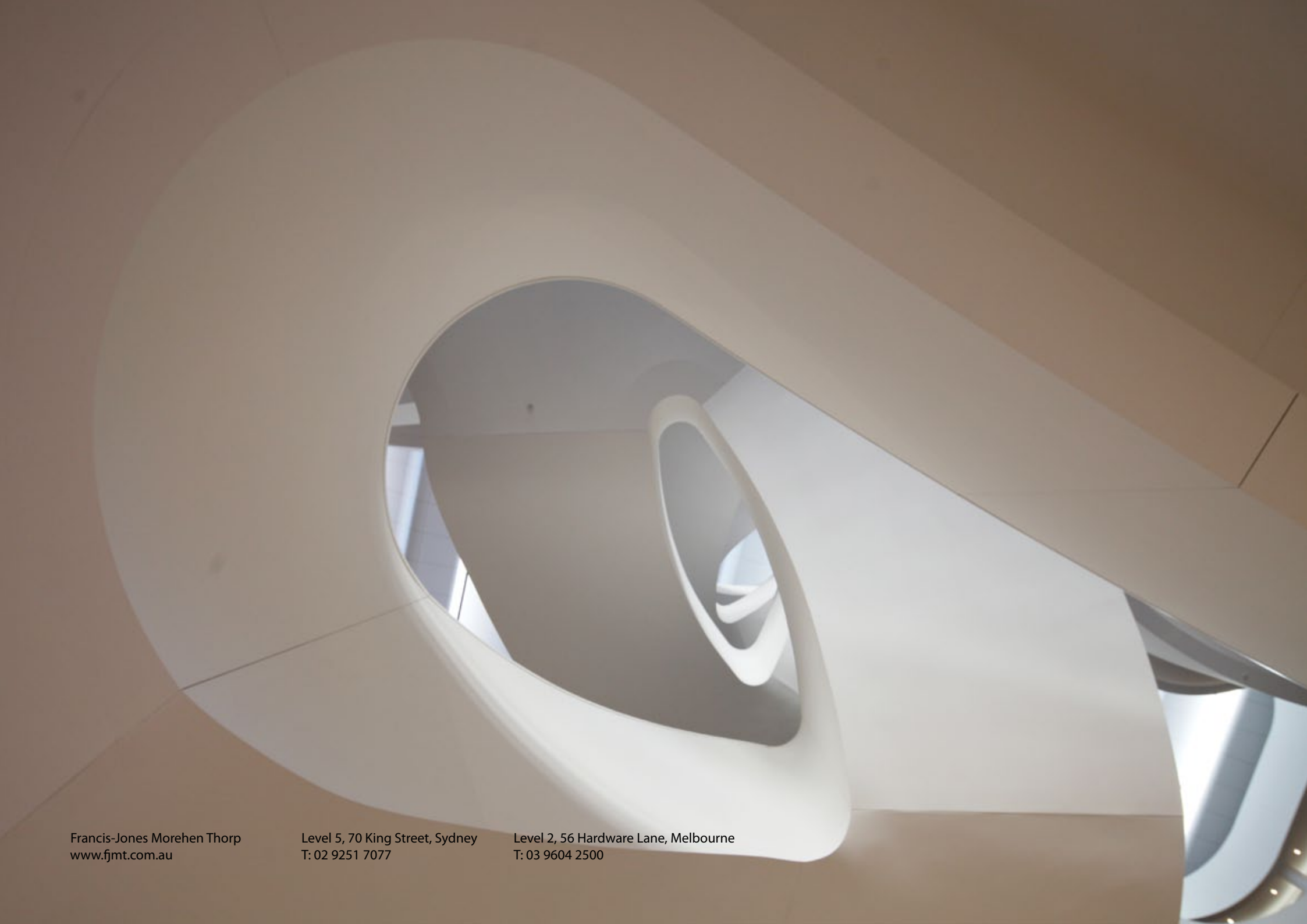

Francis-Jones Morehen Thorp  
[www.fjmt.com.au](http://www.fjmt.com.au)

Level 5, 70 King Street, Sydney  
T: 02 9251 7077

Level 2, 56 Hardware Lane, Melbourne  
T: 03 9604 2500