



CREATIVE LUXURY FURNITURE

by MAY ARRATIA

STUDIO DOSSIER
+ 2018 CATALOGUE



ART ENGINEERING DESIGN

by MAY ARRATIA



Designer and engineer **MAY ARRATIA** — Logroño, Spain 1987 — seeks to break up the monochrome, aseptic nature of spaces by creating very distinctive pieces of classical inspiration. Her **colorist exclusive designs**, manufactured with high quality materials, encourages creativity and positive thinking.

The designer has developed series of **modular parts** in different **shapes** and **colors** which work as a construction game. The art of ancient civilizations and the magical resonance of the geometry implicit in our surrounded nature is the main inspiration of all of her creations.

Undoubtedly, this is a new vision of **luxury contemporary furniture**. A combination of creative imagination and innovative technical solutions. Timeless designs with a ludic spirit, objects that are jewels brimming with luminosity!

TIMELESS DESIGNS
with a LUDIC SPIRIT

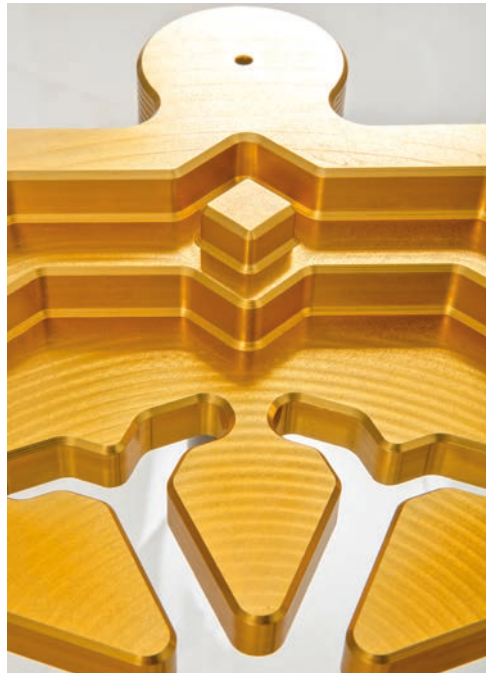

THE STUDIO

MAY ARRATIA
ESTUDIO

MAY ARRATIA studio + showroom is located in Logroño, the capital city of La Rioja in the north of Spain.

Our focus is the **design and manufacturing** of high-end creative furniture. Equally, we develop **customized projects** — for business facilities, hotels or individual clients —, combining anodized solid aluminum with other high quality eco-friendly materials.

Our mission is to continue developing **innovative technical solutions** to create unique **timeless designs**, unencumbered by transitory trends or fashions, keeping a perfect balance between art and function.

CREATIVE LUXURY
FURNITURE
made in LA RIOJA - SPAIN





MYKONOS MODULAR LAMP / MYKONOS SOFA / ATENAS SCULPTURE-TABLE / LINDARAJA CANDLEHOLDER by MAY ARATIA



ATENAS SIDE TABLE



Artistic side table with a **sculpture**/base composed of five robust pieces of solid aluminum. The design is finished with a 10mm tempered glass in an organic shape.

Main structure's color can be customized, as well as glass shape and size.

This table, with a chaotic feel, has an element of surprise when you look inside and discover a series of concentric cylindrical voids, a hypnotic effect reminiscent of the usual configuration of a Greek amphitheater.

Limited series. All our pieces are manufactured upon request exclusively for each of our customers and includes your name and series number.

MATERIAL › HQ Solid aluminum — AW 6082 T6

DIMENSIONS › 350 x 500 x 500 mm aprox.

WEIGHT › 130 kg aprox.

COLORS › available in 14 anodize color combinations

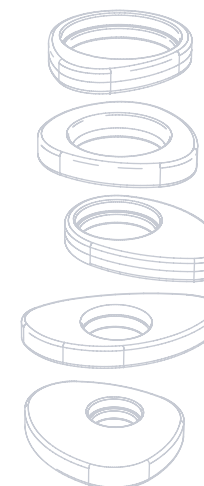

MYKONOS MODULAR
DESIGN CREATIONS

M&A



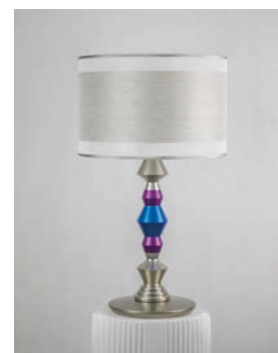
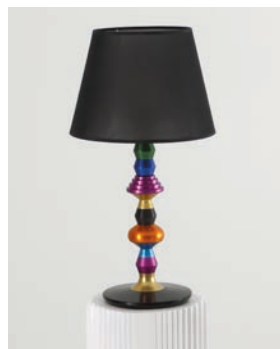
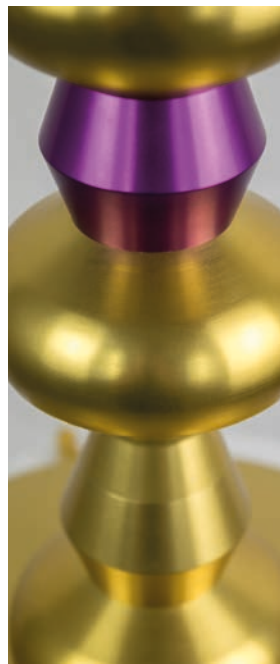

MYKONOS LUMINARIES



MODULAR DESIGN

The possibilities of design variations are very broad with the versatile **MYKONOS modules**, alternating the number, shape and color of the pieces to configure each lamp. Also, the height of the main pole and lampshade is customizable

Select a **pre-established design** from our catalog, personalizing only the color combination, or create an exclusive model with our help.

Limited series. All our pieces are manufactured upon request exclusively for each of our customers and includes name and series number.

MYKONOS MODULES > 8 modular shapes to combine



STRUCTURE MATERIAL > Solid aluminum — AW 6082 T6

LAMPSHADE > customizable lampshade style and textile

SIZE > 27 x 27 x 497 mm — medium size

WEIGHT > variable

COLORS > 14 anodize colors to choose from

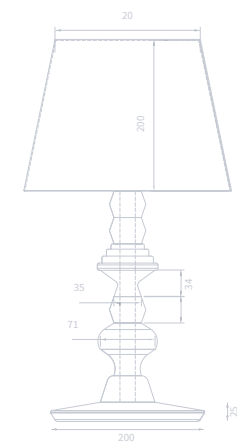
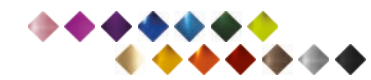





MYKONOS VASES

The Mykonos vase is created with two modules of high-quality solid aluminum, assembled with precision threads. The Mykonos modules, and its infinite combination possibilities, recall the skyline of the heavenly Greek islands.

Customizable color combinations.

Limited series. All our pieces are manufactured upon request exclusively for each of our customers and includes your name and series number.

MYKONOS MODULES > 8 available combinations



MATERIAL > HQ Solid aluminum — AW 6082 T6

SIZE > 155 x 150 mm approx.

WEIGHT > 3,5 kg approx.

COLORS > available in 14 anodize color combinations

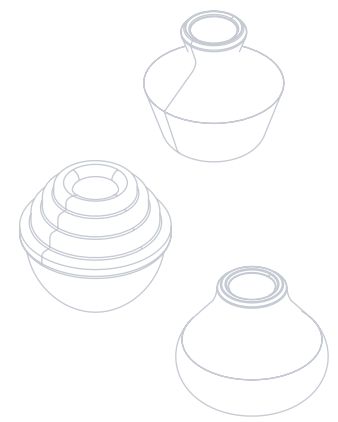
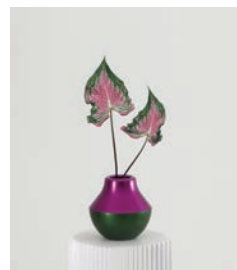





MYKONOS CANDLEHOLDERS



MODULAR DESIGN

The possibilities of design variations are very broad with the versatile **MYKONOS modules**, alternating the number, shape and color of the pieces to configure each candleholder.

Our customers can select a **pre-established design** from our catalog, personalizing only the color combination or, create their own exclusive model with our help.

Limited series. All our pieces are manufactured upon request exclusively for each of our customers and includes name and series number.

MYKONOS MODULES > 8 modular shapes to combine



MATERIAL > HQ Solid aluminum — AW 6082 T6

SIZE > 75 ø x 150 mm aprox. / variable height

WEIGHT > 3,5 kg aprox.

COLORS > available in 14 anodize color combinations

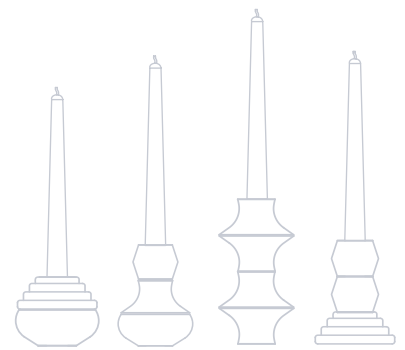

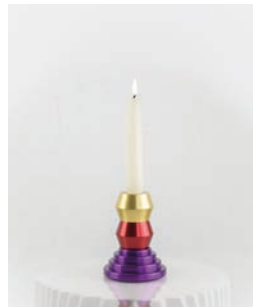
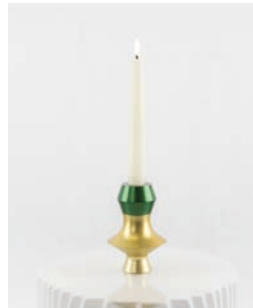





MYKONOS SOFA



Sofa of sinuous forms with modular legs built with five Mykonos modules.

This sofa has solid aluminum legs and velvet upholstery, both of which can be customized on customer request.

Limited series. All our pieces are manufactured upon request exclusively for each of our customers and includes your name and series number.

MYKONOS MODULES > 8 modules to build the legs



MATERIAL > HQ Solid aluminum — AW 6082 T6 / VELVET

SIZE > 155 x 150 mm aprox.

WEIGHT > 60 kg aprox.

COLORS > available in 14 anodize color combinations

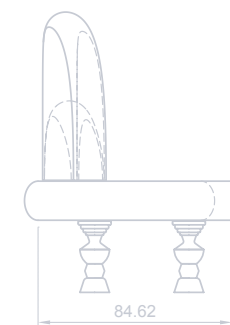
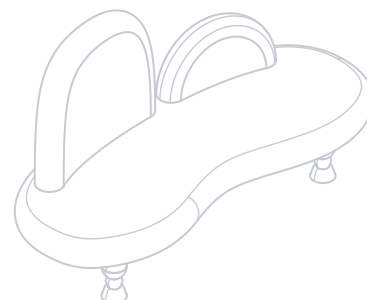
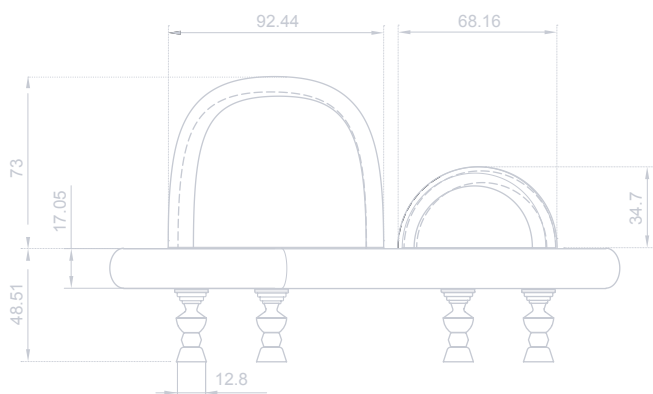

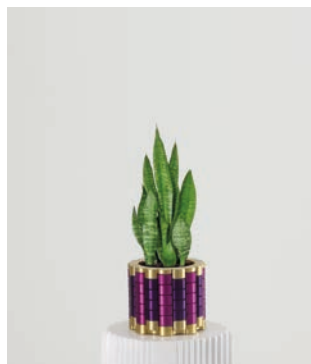

DELOS VASES



This modular vase is made of identical high precised modules, a mesmerizing work of art inspired by the greek island Delos and its ancient myths.

MODULAR DESIGN

The design possibilities are very wide, varying the number of modules to obtain different vase heights and, choosing the anodizing color combinations.

Limited series. All our pieces are manufactured upon request exclusively for each of our customers and includes your name and series number.

MATERIAL › HQ Solid aluminum — AW 6082 T6

DIMENSIONS › 150 Ø / variable height

WEIGHT › variable

COLORS › available in 14 anodize color combinations

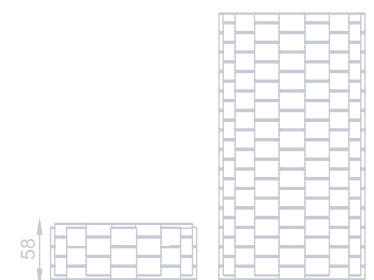
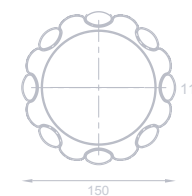

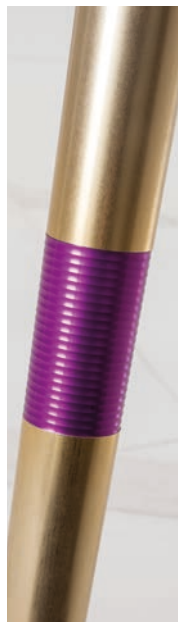

GENERALIFE TABLE



Dining table structure constructed with a robust piece of machined aeronautical quality solid aluminum, with turned legs of the same material.

Assembly without the need for tools or screws.

Color scheme can be combined as your own preference. Glass shape and size is completely bespoke to suit any space

Limited series. All our pieces are manufactured upon request exclusively for each of our customers and includes series number.

MATERIAL > HQ Solid aluminum — AW 6082 T6

DIMENSIONS > 120 x 120 x 719.6 mm aprox.

WEIGHT > 40 Kgs. aprox.

COLORS > available in 14 anodize color combinations

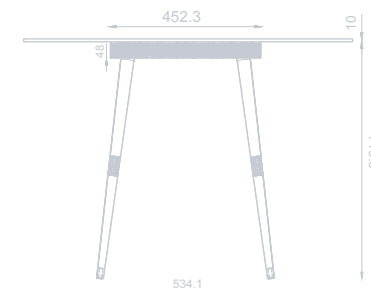
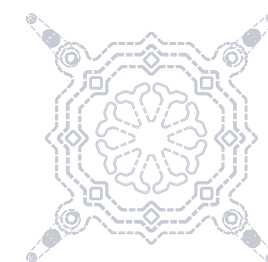





LINDARAJA CANDLEHOLDER



Candleholder with cantilever effect, evocative of the viewpoint of *Lin-dar-aixa* — the eyes of the lady's house — of the **Alhambra palace** in Granada, Spain. The octagram or eight-pointed star is a symbol of fullness and regeneration.

Limited series. All our pieces are manufactured upon request exclusively for each of our customers and includes your name and series number.

MATERIAL › HQ Solid aluminum — AW 6082 T6

DIMENSIONS › 150 x 150 x 532 mm mm aprox.

WEIGHT › 500 graprox.

COLORS › available in 14 anodize color combinations

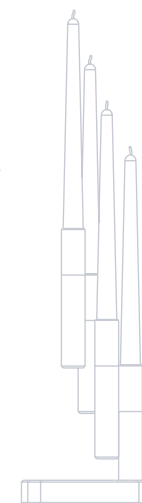
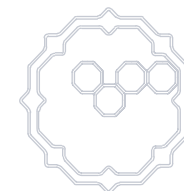



ARRAYANES STOOL



Cylindrical methacrylate stool with aeronautical quality solid aluminum seat that contains a velvet cushion.

This seat is characterized by its **light and innovative appearance**. It has been created to be part of any room as a differentiating, functional but singular complement.

Customizable color combinations.

Limited series. All our pieces are manufactured upon request exclusively for each of our customers and includes series number.

MATERIAL › HQ Solid aluminum — AW 6082 T6 / PMMA

DIMENSIONS › 300 x 300 x 500 mm aprox.

WEIGHT › 5.5 Kg aprox.

COLORS › available in 14 anodize color combinations

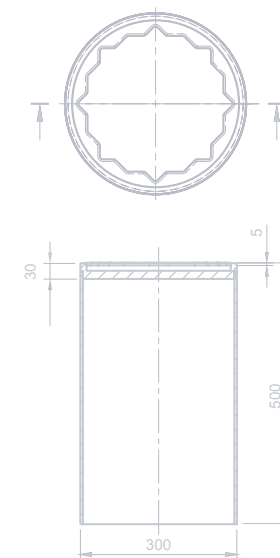
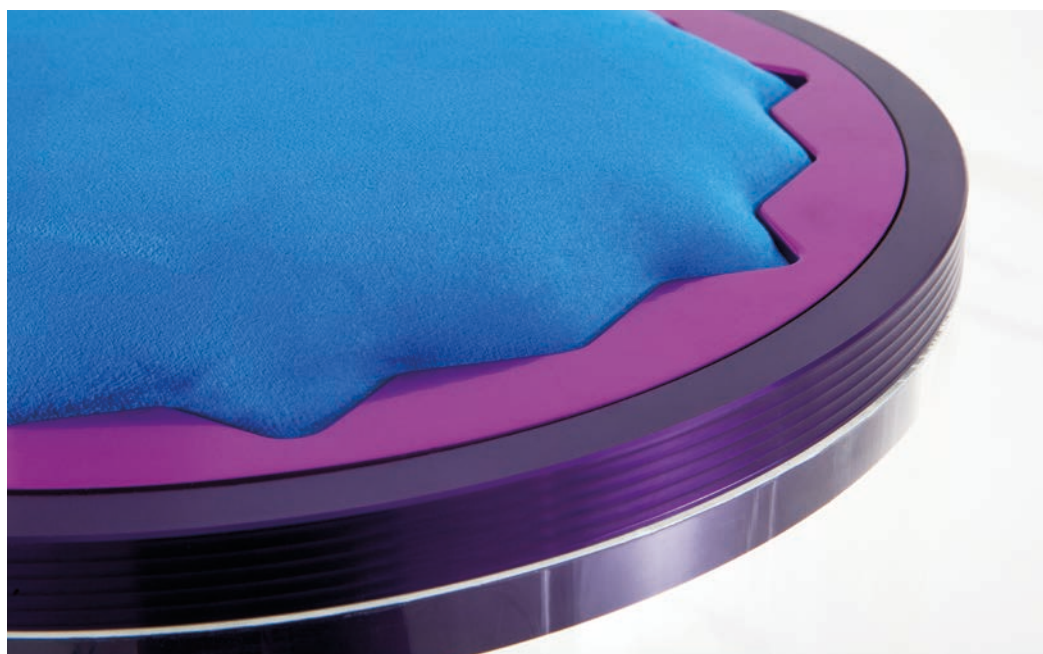



EXPERIENCED
MANUFACTURERS
+ HIGH QUALITY MATERIALS

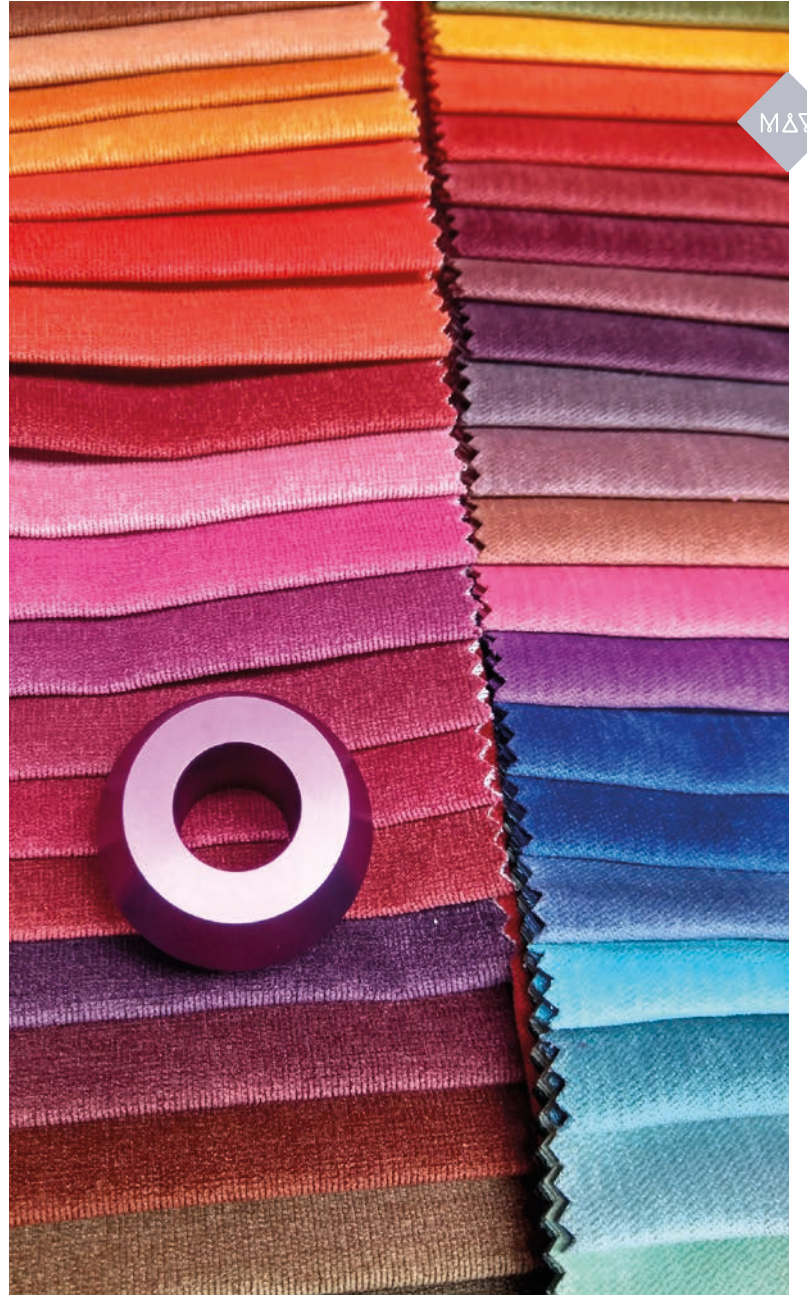

MATERIALS + MANUFACTURING PROCESS



HQ SOLID ALUMINUM

The aluminum we use (quality 6082/6061) is commonly applied in the aeronautical industry for the manufacture of tools, due to its characteristics of strength, hardness, weight and resistance.

ECO-FRIENDLY

Solid aluminum is **100% recyclable** and plays a fundamental role in human ecology, in addition to having an excellent machining behavior and satisfactory results in terms of subsequent anodising.

OTHER TOP QUALITY MATERIALS

Although solid aluminum is the main focus of our studio, we are developing new designs that incorporate other materials such as marble, wood, glass and ceramics.

MACHINING

All of our solid aluminum pieces are manufactured at the **ARRATIA's machining workshop** — by turning and CNC milling — located in the north of Spain; a family business with **70 years of expertise and experience in the field.**

This manufacturing process is governed by the standards that are used in the sectors of industrial machinery, automotive and aeronautics.

All in all, **MAY ARRATIA** achieves a **perfect balance between technology and art** applying those processes in each and unique creation.





ANODIZE - WE BELIEVE IN COLOR! by MAY ARRATIA ♦ www.mayarratia.com



ANODIZED WE BELIEVE IN COLOR!

Since ancient times, it is well known that colors have a vibratory energy that can influence human beings in different ways. From warmer and cheerful palettes to more neutral or colder tones, **color plays a fundamental role in our studio.**

ANODIZATION PROCESS

Anodized is a treatment capable of achieving a layer of aluminum oxide on the surface of the material, by means of an electrochemical process.

This treatment increases the surface hardness of the aluminum, **coloring the material** but keeping the drawings that are created on the surface when mechanized, making each piece a **unique object** full of nuances.

“Colors are the mother tongue of the subconscious.”

GUSTAV CARL JUNG



SHOWROOM

Calle Villamediana 15, bajo
26001 - Logroño, La Rioja
SPAIN

T. +34 941 571 300

MAYTE ARRATIA
ENGINEER / HEAD DESIGNER

may@mayarratia.com

CARLOS ARRATIA
PRODUCTION DEPT.

info@mayarratia.com

MÓNICA DI FRANCESCO
MARKETING DEPT. / GRAPHIC DESIGN

marketing@mayarratia.com